

Water Specialist

WS1 and WS1.25 Drawings and Service Manual

1" Control Valve Series Model: WS1

1.25" Control Valve Series Model: WS1.25

Operation and Instruction Manual for OEM Only.

Please Note: This operation and instruction manual is for the training of the OEM and for the OEM to use to train their customers. This document is not to be used as the complete system manual.

HYDROCARBONS SUCH AS KEROSENE, BENZENE, GASOLINE, ETC., MAY DAMAGE PRODUCTS THAT CONTAIN O-RINGS OR PLASTIC COMPONENTS. EXPOSURE TO SUCH HYDROCARBONS MAY CAUSE THE PRODUCTS TO LEAK. DO NOT USE THE PRODUCT(S) CONTAINED IN THIS DOCUMENT ON WATER SUPPLIES THAT CONTAIN HYDROCARBONS SUCH AS KEROSENE, BENZENE, GASOLINE, ETC.



Table of Contents

Valve Body Compliance Table	4
WS1 and WS1.25 Identification	5
WS1 Drive Cap Assembly, Downflow Piston, Upflow Piston, Regenerant Piston and Spacer Stack Assembly	6
WS1.25 Drive Cap Assembly, Downflow Piston, Upflow Piston, Regenerant Piston and Spacer Stack Assembly	7
Injector Cap, Injector Screen, Injector, Plug and O-Ring	8
Injector Order Information	9
Injector Graphs US Units: Injector Draw, Slow Rinse and Total Flow Rates	10
Injector Graphs Metric Units: Injector Draw, Slow Rinse and Total Flow Rates	12
Refill Flow Control Assembly and Refill Port Plug	14
Drain Line – 3/4”	15
Drain Line – 1”	16
Water Meter, Meter Plug and Mixing Valve	17
Installation Fitting Assemblies	18
Bypass Valve	20
Flow Diagrams – Service and Backwash	21
Flow Diagrams – Downflow and Upflow	22
Flow Diagrams – Rinse and Fill	23
WS1 Service Spanner Wrench	24
General Information	25
General Warnings (Must appear in OEM’s manual)	25
Specifications which must be included in OEM’s Manual	27
Quick Reference Specifications	27
Drive Assembly	28
Drive Cap Assembly, Main Piston and Regenerant Piston	28
Spacer Stack Assembly	29
Injector Cap, Screen, Injector Plug and Injector	29
Refill Flow Control Assembly or Refill Port Plug	29
Drain Line Flow Control and Fitting Assembly	30
Water Meter or Meter Plug	31
Mixing Valve	31
Installation Fitting Assemblies	31
Bypass Valve	32
Installation	34
Service Instructions	36
Troubleshooting	41
Limited Warranty	44

Valve Body Compliance Table

Application	Injector and/or Plug(s)	Main Piston	Regenerant Piston	Stack	Body*
1" Downflow Softener or Regenerating Filter	Injector in "DN" hole, Plug in "UP" hole	V3011	V3174	V3005	V3001, V3001-01 (QC1), V3001-02 (Mixing), V3001-03 (Mixing QC1), V3001-04 (QC2) or V3001-06 (Mixing QC-2)
1" Backwash Only Filter	Plug in "DN" and "UP" holes, Install Refill Port Plug	V3011	None	V3005	V3001, V3001-01 (QC1), V3001-02 (Mixing), V3001-03 (Mixing QC1), V3001-04 (QC2) or V3001-06 (Mixing QC-2)
1" Upflow Softener	Injector in "UP" hole, Plug in unlabeled hole	V3011-01	V3174	V3005	V3001UP, V3001-01UP (QC1), V3001-02UP (Mixing), V3001-03UP (Mixing QC1), V3001-04UP (QC2) or V3001-06UP (Mixing QC-2)
1.25" Downflow Softener or Regenerating Filter (1.32" Distributor)	Injector in "DN" hole, Plug in "UP" hole	V3407	V3174	V3430	V3020 or V3020-01 (Mixing)
1.25" Backwash Only Filter (1.32" Distributor)	Injector in "DN" hole, Plug in "UP" hole	V3407	None	V3430	V3020 or V3020-01 (Mixing)
1.25" Downflow Softener or Regenerating Filter (32mm Distributor)	Plug in "DN" and "UP" holes, Install Refill Port Plug	V3407	V3174	V3430	V3020-02 or V3020-03 (Mixing)
1.25" Backwash Only Filter (32mm Distributor)	Plug in "DN" and "UP" holes, Install Refill Port Plug	V3407	None	V3430	V3020-02 or V3020-03 (Mixing)
1.25" Upflow (1.32" Distributor)	Injector in "UP" hole, Plug in unlabeled hole	V4042	V3174	V3430	V3020UP or V3020-01UP (Mixing)
1.25" Upflow (32mm Distributor)	Injector in "UP" hole, Plug in unlabeled hole	V4042	V3174	V3430	V3020-02UP or V3020-03UP (Mixing)

QC1 and QC2 bodies are only available if referenced in the programming guide for that software.

WS1 & WS1.25 Identification Figure

WS1 with 1.050" Distributor Tube Opening Identification

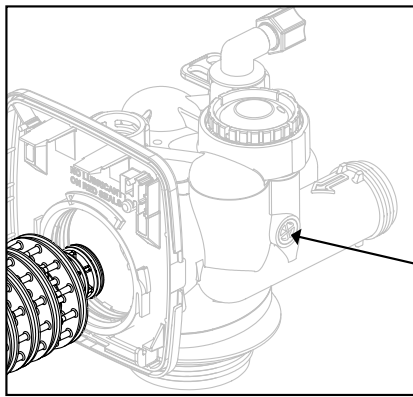

Black Plug

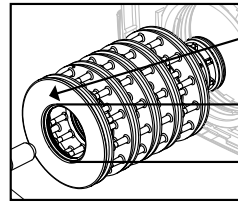

Spacer Color:
Grey

1.25"

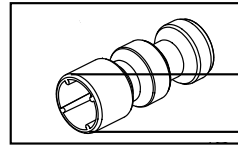

1.25"

Note: The WS1 downflow piston is a solid amber color. The WS1 upflow piston is black and amber.

WS1.25 with 1.32" Distributor Tube Opening Identification

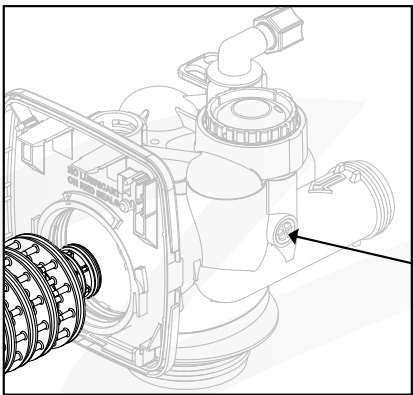

Grey Plug

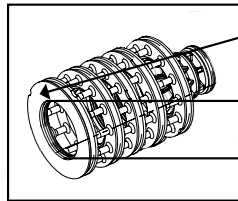

Spacer Color:
Black

1.5"

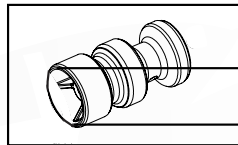

1.5"

Note: The WS1.25 downflow piston is a solid amber color. The WS1.25 upflow piston is a solid black color.

WS1.25 with 32mm Distributor Tube Opening Identification

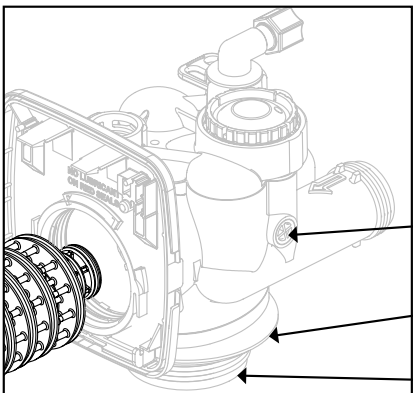

Grey Plug

Grey Ring

Grey
Distributor
O-ring
Retainer

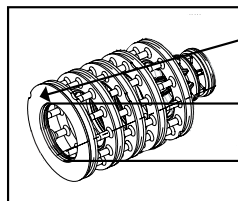

Spacer Color:
Black

1.5"

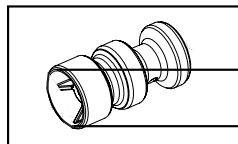

1.5"

Note: The WS1.25 downflow piston is a solid amber color. The WS1.25 upflow piston is a solid black color.

WS1 Drive Cap Assembly, Downflow Piston, Upflow Piston, Regenerant Piston and Spacer Stack Assembly

Drawing No.	Order No.	Description	Quantity
1	V3005	WS1 Spacer Stack Assembly	1
2	V3004	Drive Cap ASY	1
3	Back Plate	Refer to Programming and Cover Drawing Manual	1
4a	V3011*	WS1 Piston Downflow ASY	1
4b	V3011-01*	WS1 Piston Upflow ASY	
5	V3174	WS1 Regenerant Piston	1
6	V3135	O-ring 228	1
7	V3180	O-ring 337	1
8	V3105	O-ring 215 (Distributor Tube)	1
Not Shown	V3001	WS1 Body ASY Downflow	1
	V3001-02	WS1 Mixing Valve Body ASY	
	V3001UP	WS1 Body ASY Upflow	
	V3001-02UP	WS1 Mixing Valve Body Upflow ASY	

*V3011 is labeled with DN and V3011-01 is labeled with UP. Upflow option is not applicable to EE, EI or TC control valves.
 Note: The regenerant piston is not used in backwash only applications.

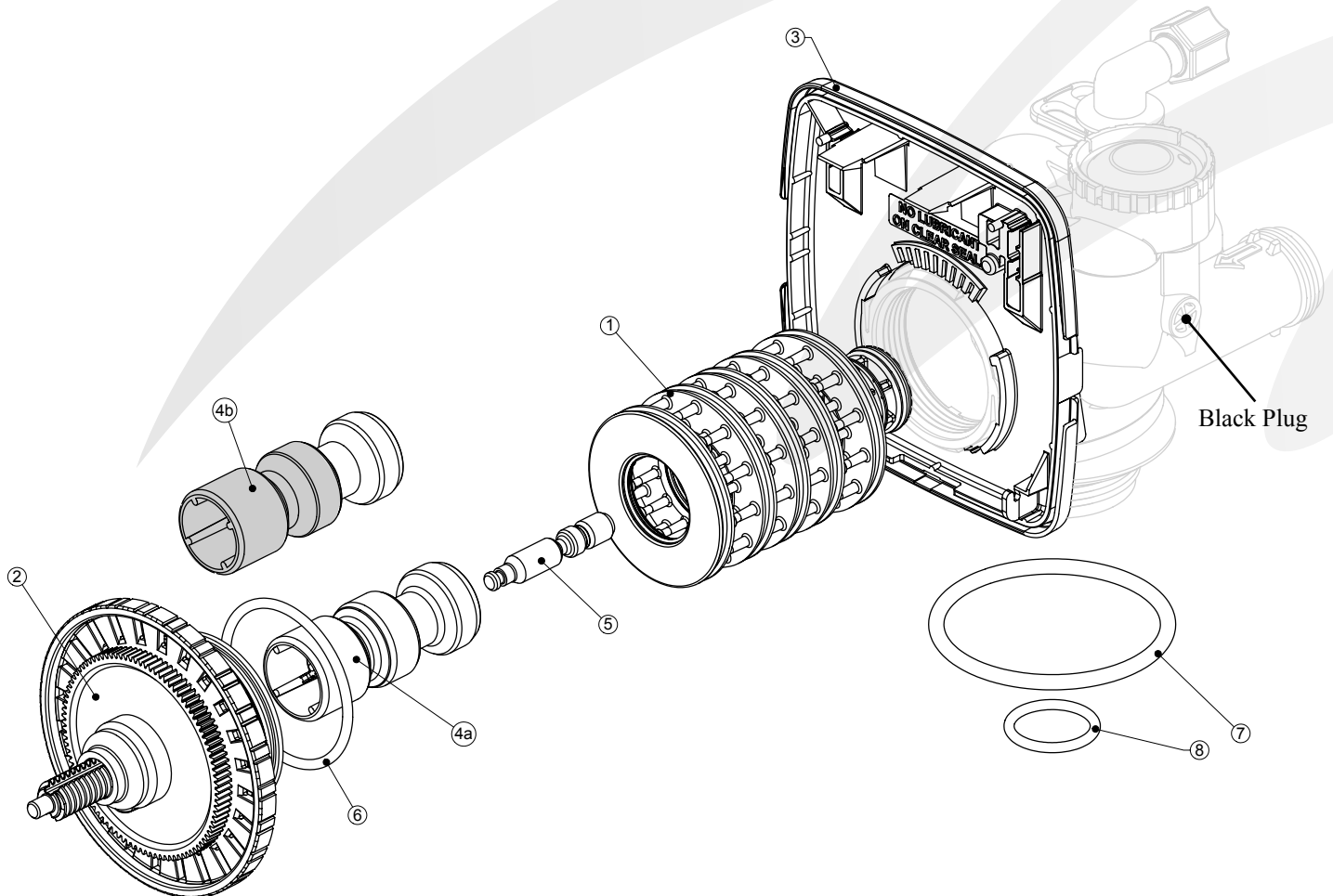

WS1.25 Drive Cap Assembly, Downflow Piston, Upflow Piston, Regenerant Piston and Spacer Stack Assembly

Drawing No.	Order No.	Description	Quantity
1	V3430	WS1.5 Spacer Stack Assembly	1
2	V3004	Drive Cap ASY	1
3	Back Plate	Refer to Programming and Cover Drawing Manual	1
4	V3407	WS125/15 Piston Downflow ASY (amber)	1
	V4042	WS125/15 Piston Upflow ASY (black in color)	
5	V3174	WS1 Regenerant Piston	1
6	V3135	O-ring 228	1
7	V3180	O-ring 337	1
8	V3358	O-ring 219 (Distributor Tube Opening 1.32")	1
	V3357	O-ring 218 (Distributor Tube Opening 32mm)	
Not Shown	V3020	WS1.25 Body ASY Downflow (Distributor Tube Opening 1.32")	1
	V3020-01	WS1.25 Mixing Valve Body Downflow ASY (Distributor Tube Opening 1.32")	
	V3020-02	WS1.25 Body ASY Downflow (Distributor Tube Opening 32mm)	
	V3020-03	WS1.25 Mixing Valve Body Downflow ASY (Distributor Tube Opening 32mm)	
	V3020UP	WS1.25 Body ASY Upflow (Distributor Tube Opening 1.32")	
	V3020-01UP	WS1.25 Mixing Valve Body Upflow ASY (Distributor Tube Opening 1.32")	
	V3020-02UP	WS1.25 Body ASY Upflow (Distributor Tube Opening 32mm)	
	V3020-03UP	WS1.25 Mixing Valve Body Upflow ASY (Distributor Tube Opening 32mm)	

Note: The regenerant piston is not used in backwash only applications.

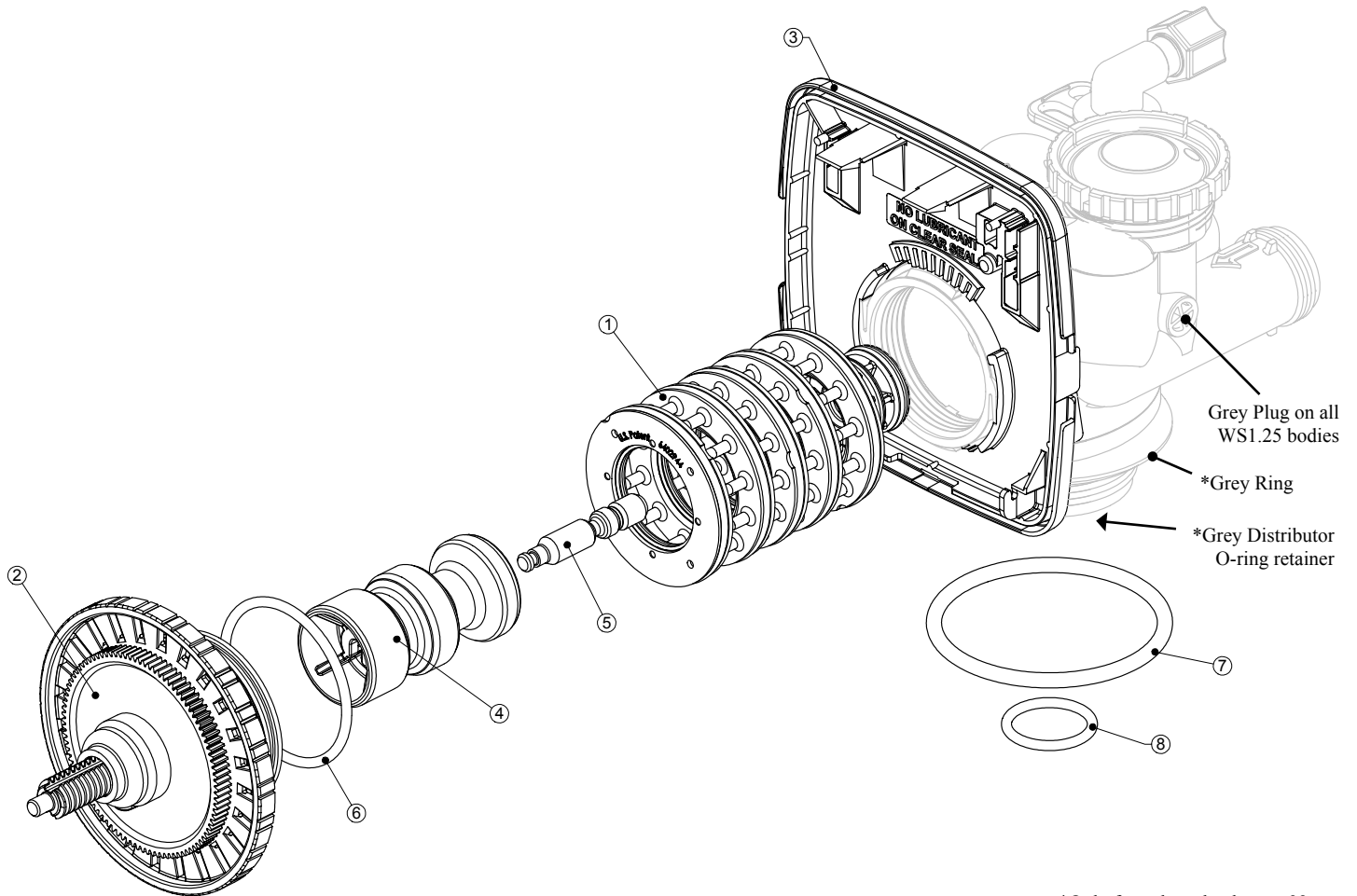

*Only for valves that have a 32mm Distributor Tube Opening

Injector Cap, Injector Screen, Injector, Plug and O-Ring

Drawing No.	Order No.	Description	Quantity
1	V3176	INJECTOR CAP	1
2	V3152	O-RING 135	1
3	V3177-01	INJECTOR SCREEN CAGE	1
4	V3010-1Z	WS1 INJECTOR ASY Z PLUG	1
5	V3010-1A	WS1 INJECTOR ASY A BLACK	1
	V3010-1B	WS1 INJECTOR ASY B BROWN	
	V3010-1C	WS1 INJECTOR ASY C VIOLET	
	V3010-1D	WS1 INJECTOR ASY D RED	
	V3010-1E	WS1 INJECTOR ASY E WHITE	
	V3010-1F	WS1 INJECTOR ASY F BLUE	
	V3010-1G	WS1 INJECTOR ASY G YELLOW	
	V3010-1H	WS1 INJECTOR ASY H GREEN	
	V3010-1I	WS1 INJECTOR ASY I ORANGE	
	V3010-1J	WS1 INJECTOR ASY J LIGHT BLUE	
	V3010-1K	WS1 INJECTOR ASY K LIGHT GREEN	
Not Shown	V3170	O-RING 011	*
Not Shown	V3171	O-RING 013	*

* The injector plug and the injector each contain one 011 (lower) and 013 (upper) o-ring.

Note: For upflow position, injector is located in the up hole and injector plug is in the other hole.
 WS1 and WS1.25 upflow bodies are identified by having the DN marking removed.
 Upflow option is not applicable to EE, EI, or TC control valves.
 For a filter that only backwashes, injector plugs are located in both holes.

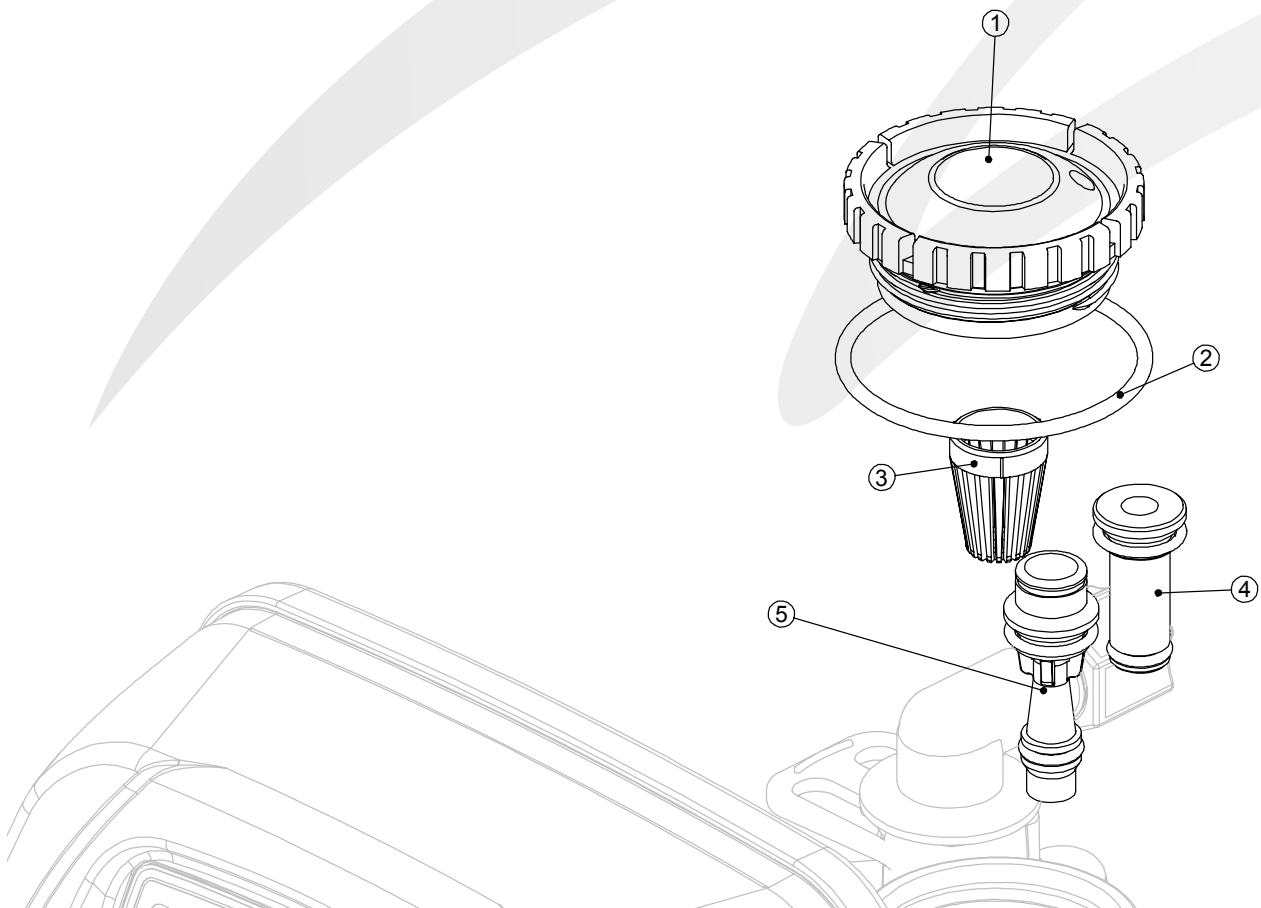

Injector Order Information

Injector Order Number	Injector Color	Typical Tank Diameter	
		Down	Up*
V3010-1A	Black	6"	8"
V3010-1B	Brown	7"	9"
V3010-1C	Violet	8"	10"
V3010-1D	Red	9"	12"
V3010-1E	White	10"	13"
V3010-1F	Blue	12"	14"
V3010-1G	Yellow	13"	16"
V3010-1H	Green	14"	18"
V3010-1I	Orange	16"	22"
V3010-1J	Light Blue	18"	
V3010-1K	Light Green	22"	

Actual tank size used may vary depending on the design and application of the system. Tank diameter is an approximation for the following:

1. Downflow softener using standard mesh synthetic cation exchange media regenerating with sodium chloride.
2. Upflow softener using standard mesh synthetic cation exchange media regenerating with sodium chloride, an inlet water pressure of 30 to 50 psi (2.1 to 3.4 bar) and water temperature of 60°F (15.6°C) water or warmer. Higher pressures or lower temperatures would need smaller injectors to avoid lifting the bed.

*Not applicable for EE, EI or TC WS1 and WS1.25 control valves.

BLACK, ORDER NO. V3010-1A
US Units

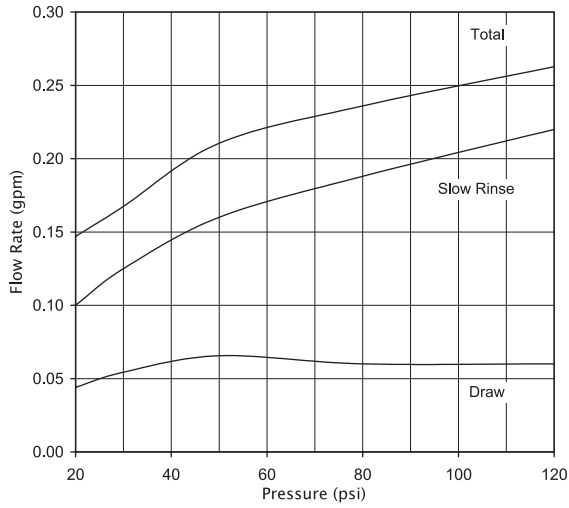

BROWN, ORDER NO. V3010-1B
US Units

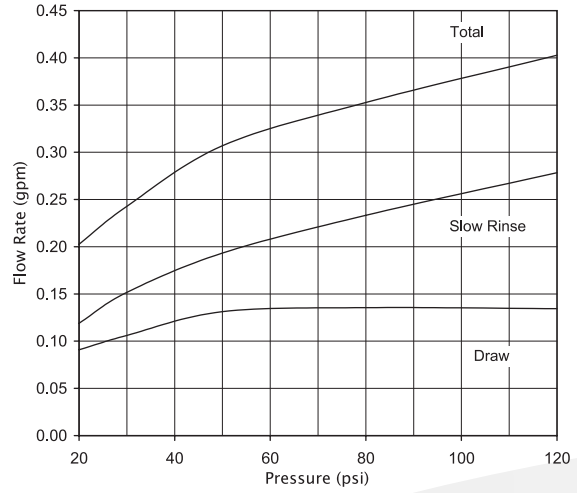

VIOLET, ORDER NO. V3010-1C
US Units

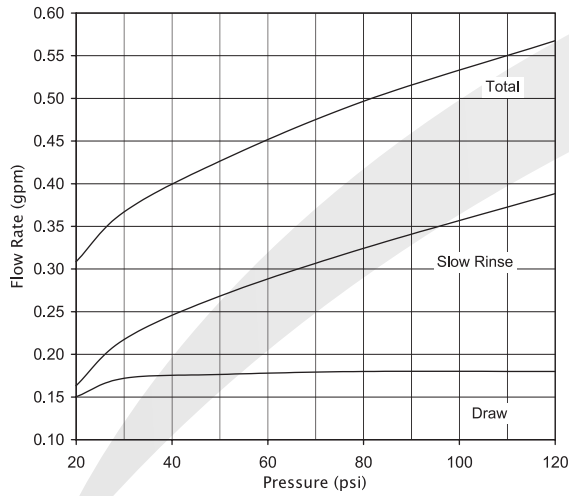

RED, ORDER NO. V3010-1D
US Units

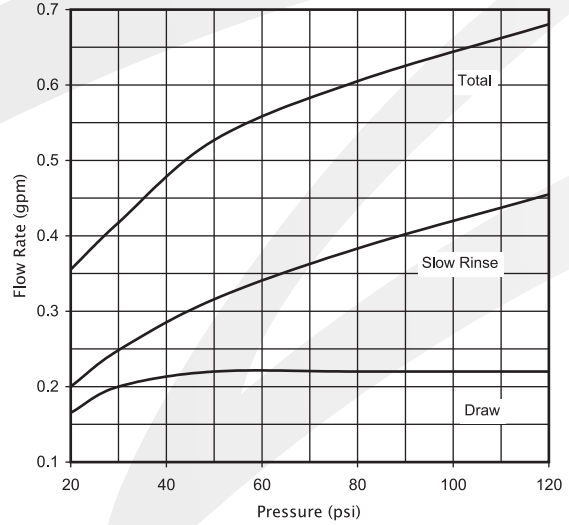

WHITE, ORDER NO. V3010-1E
US Units

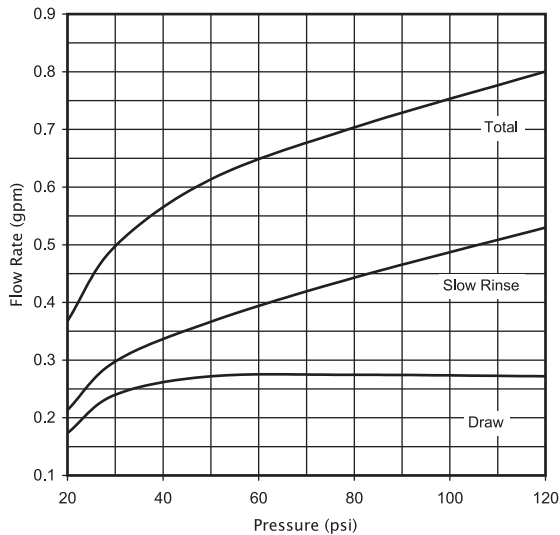

BLUE, ORDER NO. V3010-1F
US Units

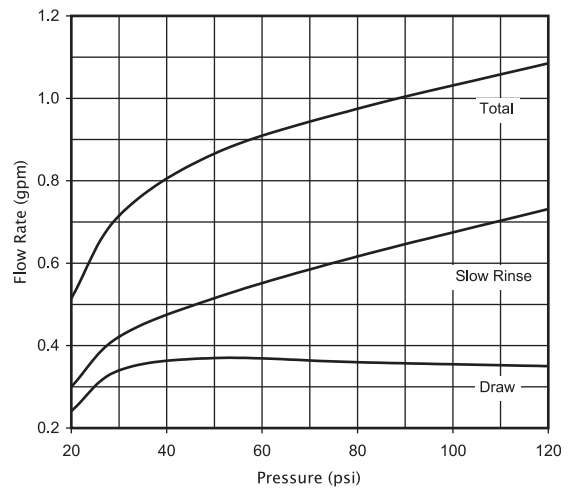

YELLOW, ORDER NO. V3010-1G
US Units

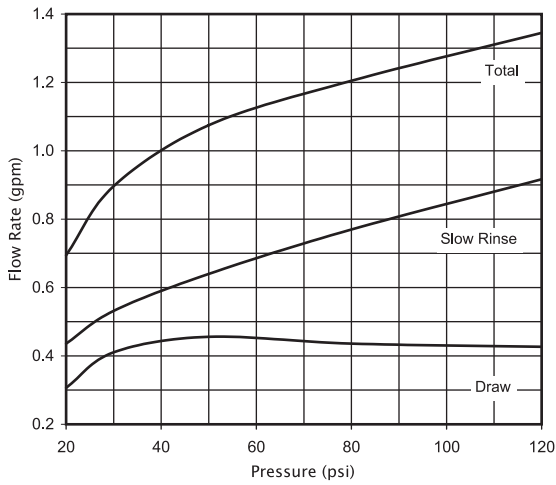

GREEN, ORDER NO. V3010-1H
US Units

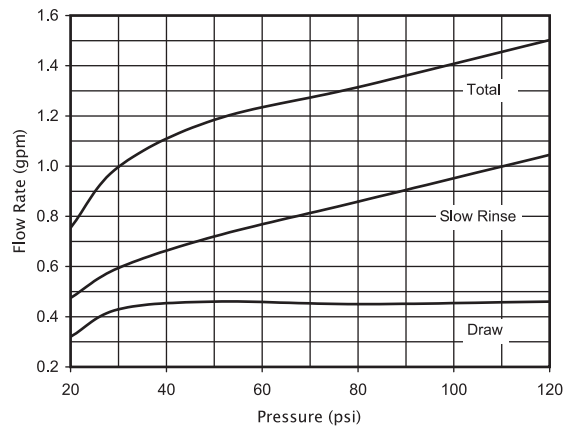

ORANGE, ORDER NO. V3010-1I
US Units

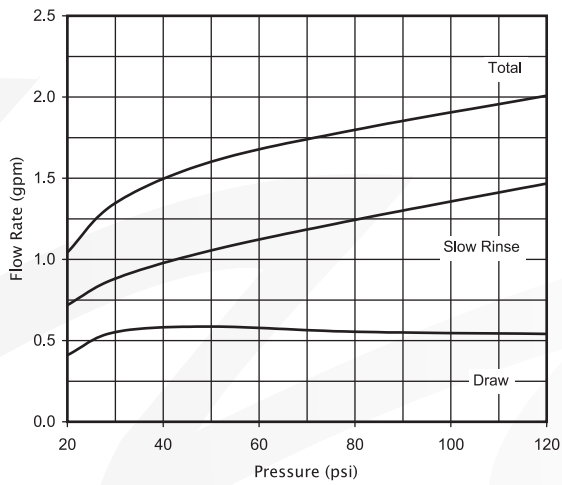

LIGHT BLUE, ORDER NO. V3010-1J
US Units

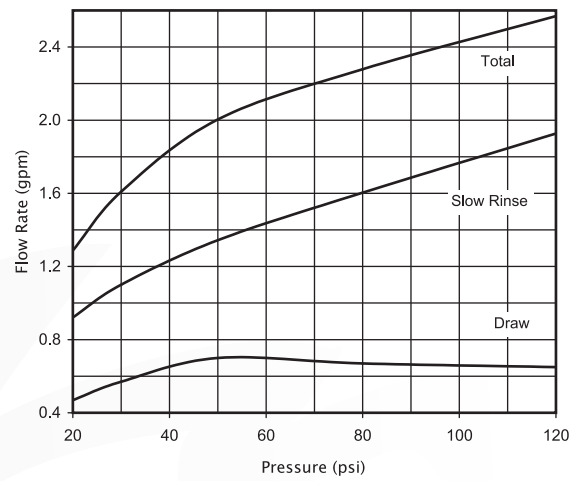

LIGHT GREEN, ORDER NO. V3010-1K
US Units

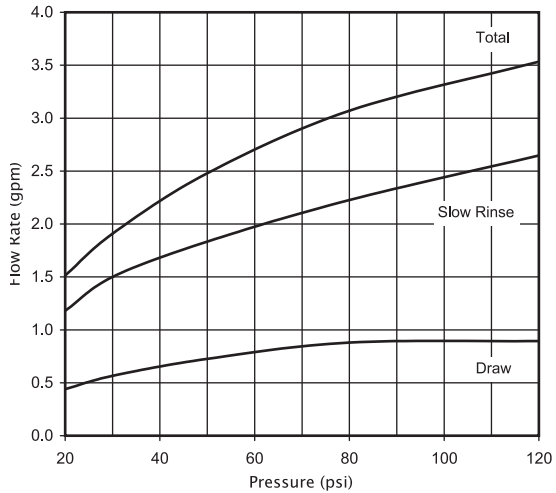

BLACK, ORDER NO. V3010-1A
Metric Units

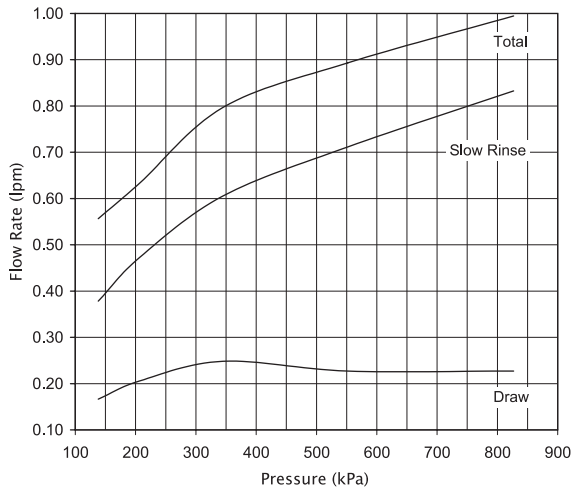

BROWN, ORDER NO. V3010-1B
Metric Units

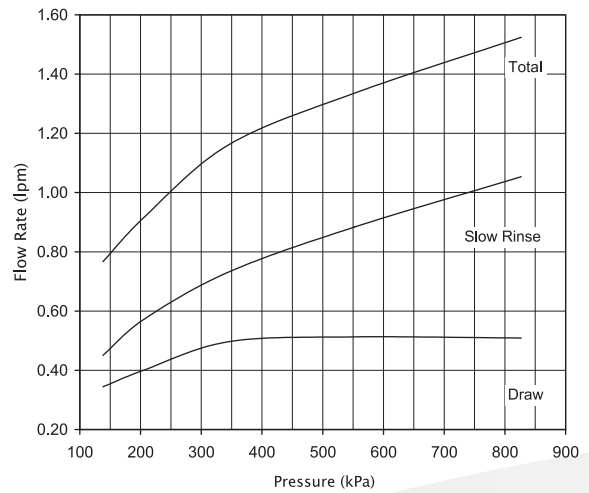

VIOLET, ORDER NO. V3010-1C
Metric Units

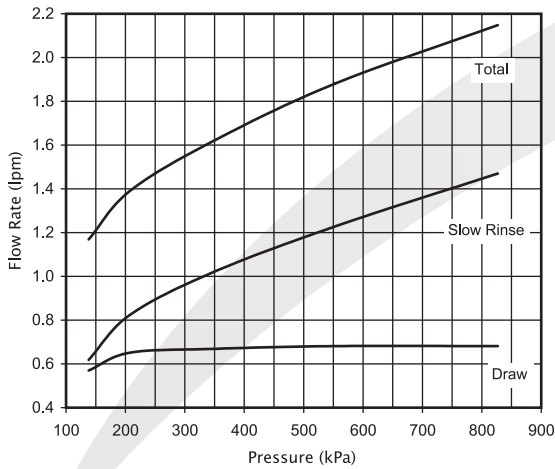

RED, ORDER NO. V3010-1D
Metric Units

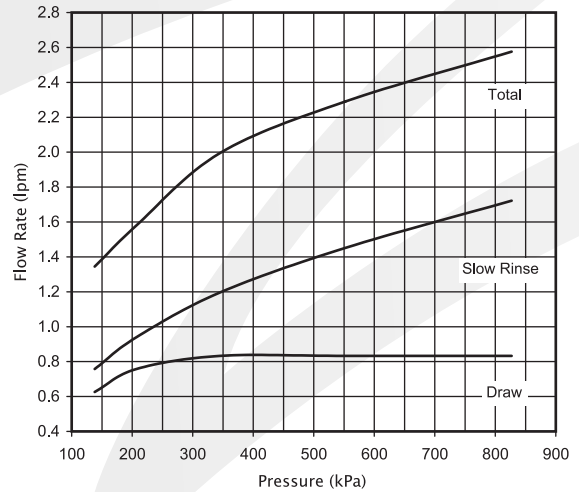

WHITE, ORDER NO. V3010-1E
Metric Units

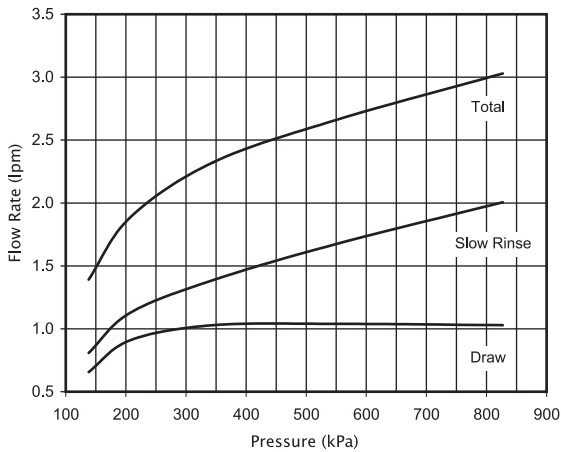

BLUE, ORDER NO. V3010-1F
Metric Units

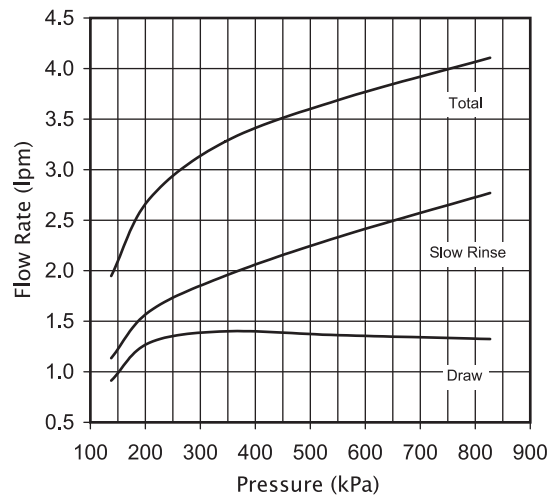

YELLOW, ORDER NO. V3010-1G
Metric Units

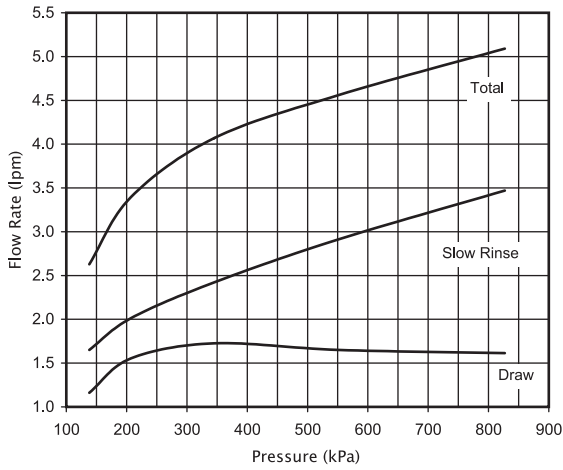

GREEN, ORDER NO. V3010-1H
Metric Units

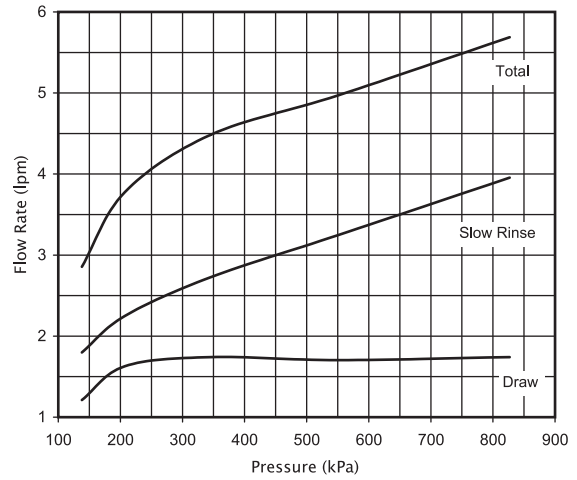

ORANGE, ORDER NO. V3010-1I
Metric Units

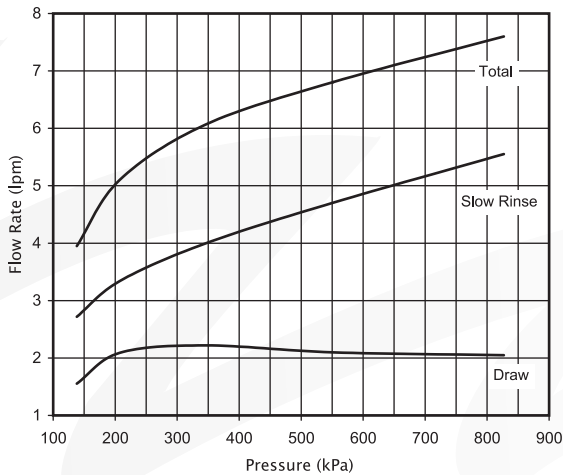

LIGHT BLUE, ORDER NO. V3010-1J
Metric Units

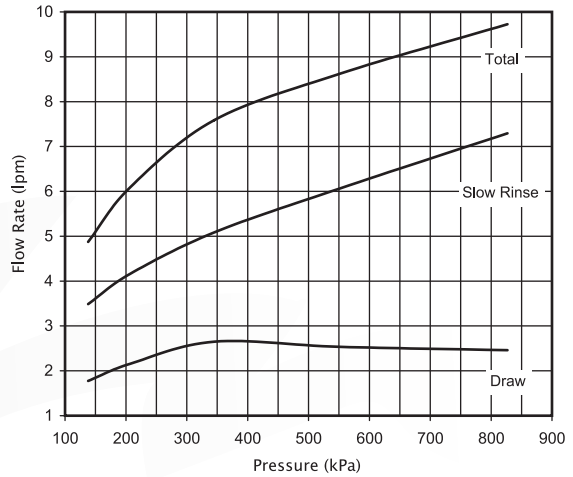

LIGHT GREEN, ORDER NO. V3010-1K
Metric Units

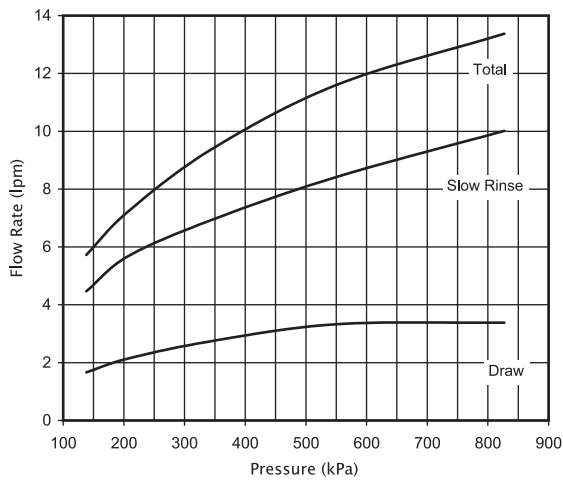

Refill Flow Control Assembly and Refill Port Plug

Drawing No.	Order No.	Description	Quantity
1	V3195-01	WS1 Refill Port Plug Asy	This part is required for backwash only systems
2	H4615	Elbow Locking Clip	1
3	JCP-P-6	Polytube insert 3/8"	1
4	JCPG-6PBLK	Nut 3/8"	1
5	H4613	Elbow Cap 3/8"	1
6	V3163	O-ring 019	1
7	V3165-01*	WS1 RFC Retainer Asy (0.5 gpm)	1
8	V3182	WS1 RFC	1
9	V3330-01	WS1 Brine Elbow Asy w/RFC 3/8"	1
Not Shown	V3552	WS1 Brine Elbow Asy w/RFC 1/2"	Option
Not Shown	H4650	Elbow 1/2" with nut and insert	Option

*Assembly includes V3182 WS1 (0.5 gpm) RFC.

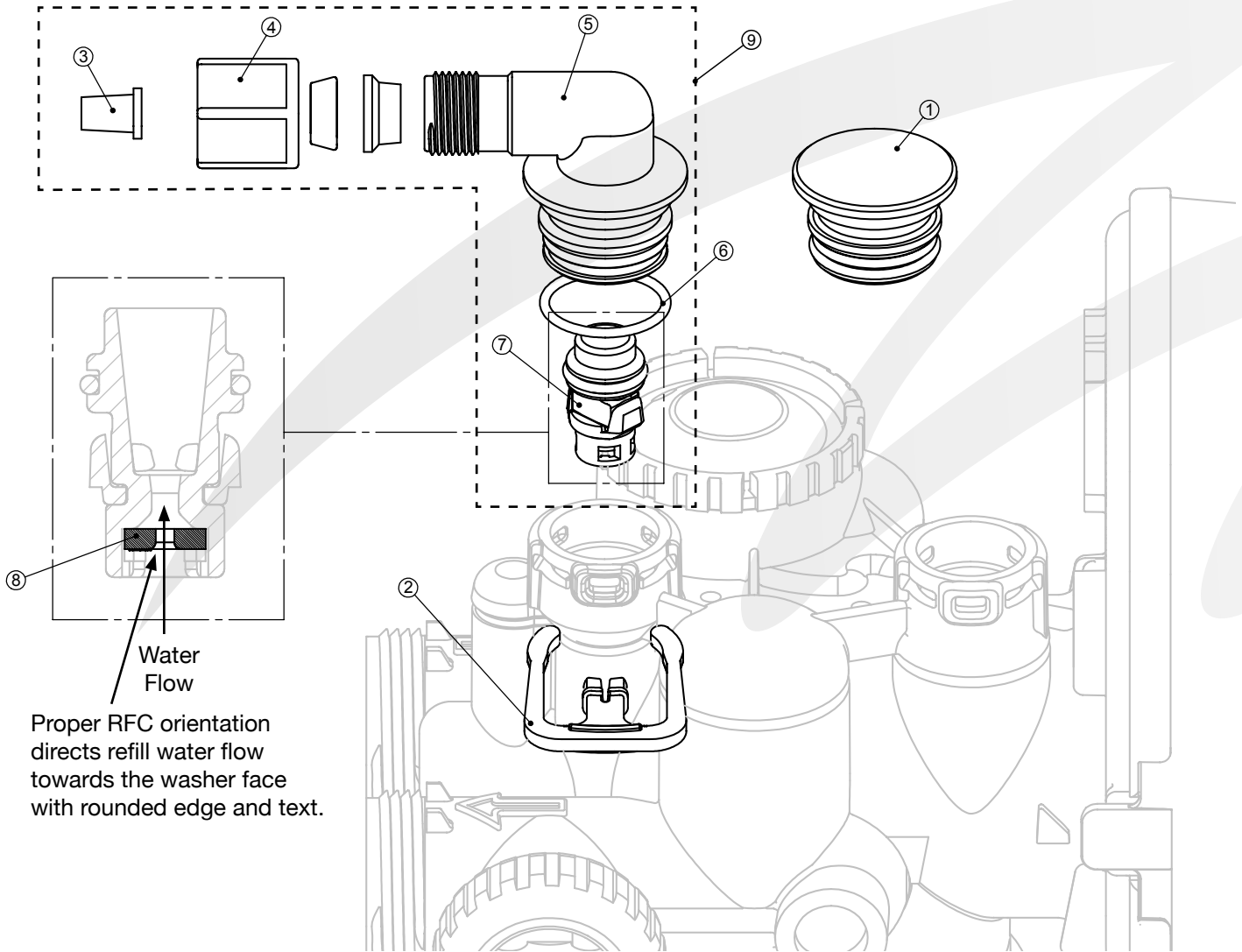

Proper RFC orientation directs refill water flow towards the washer face with rounded edge and text.

Drain Line – 3/4"

Drawing No.	Order No.	Description	Quantity
1	H4615	Elbow Locking Clip	1
2	PKP10TS8-BULK	Polytube insert 5/8	Option
3	V3192	WS1 Nut 3/4 Drain Elbow	Option
4*	V3158-01	WS1 Drain Elbow 3/4 Male	1
	V3158-02	WS1 Drain Elbow 3/4 Male No Silencer	
5	V3163	O-ring 019	1
6*	V3159-01	WS1 DLFC Retainer ASY	1
7	V3162-007	WS1 DLFC 0.7 gpm for 3/4	One DLFC must be used if 3/4 fitting is used
	V3162-010	WS1 DLFC 1.0 gpm for 3/4	
	V3162-013	WS1 DLFC 1.3 gpm for 3/4	
	V3162-017	WS1 DLFC 1.7 gpm for 3/4	
	V3162-022	WS1 DLFC 2.2 gpm for 3/4	
	V3162-027	WS1 DLFC 2.7 gpm for 3/4	
	V3162-032	WS1 DLFC 3.2 gpm for 3/4	
	V3162-042	WS1 DLFC 4.2 gpm for 3/4	
	V3162-053	WS1 DLFC 5.3 gpm for 3/4	
	V3162-065	WS1 DLFC 6.5 gpm for 3/4	
	V3162-075	WS1 DLFC 7.5 gpm for 3/4	
	V3162-090	WS1 DLFC 9.0 gpm for 3/4	
V3162-100	WS1 DLFC 10.0 gpm for 3/4		

*4 and 6 can be ordered as a complete assembly: V4057 WS1 DRN ELBOW&RETAIN W/SIL ASY or V3962 WS1 DRN ELB&RETAIN WO/SIL ASY

Valves are shipped without drain line flow control (DLFC) - install DLFC before using. Valves are shipped without 3/4 nut for drain elbow (polytube installation only) and 5/8" polytube insert (polytube installation only).

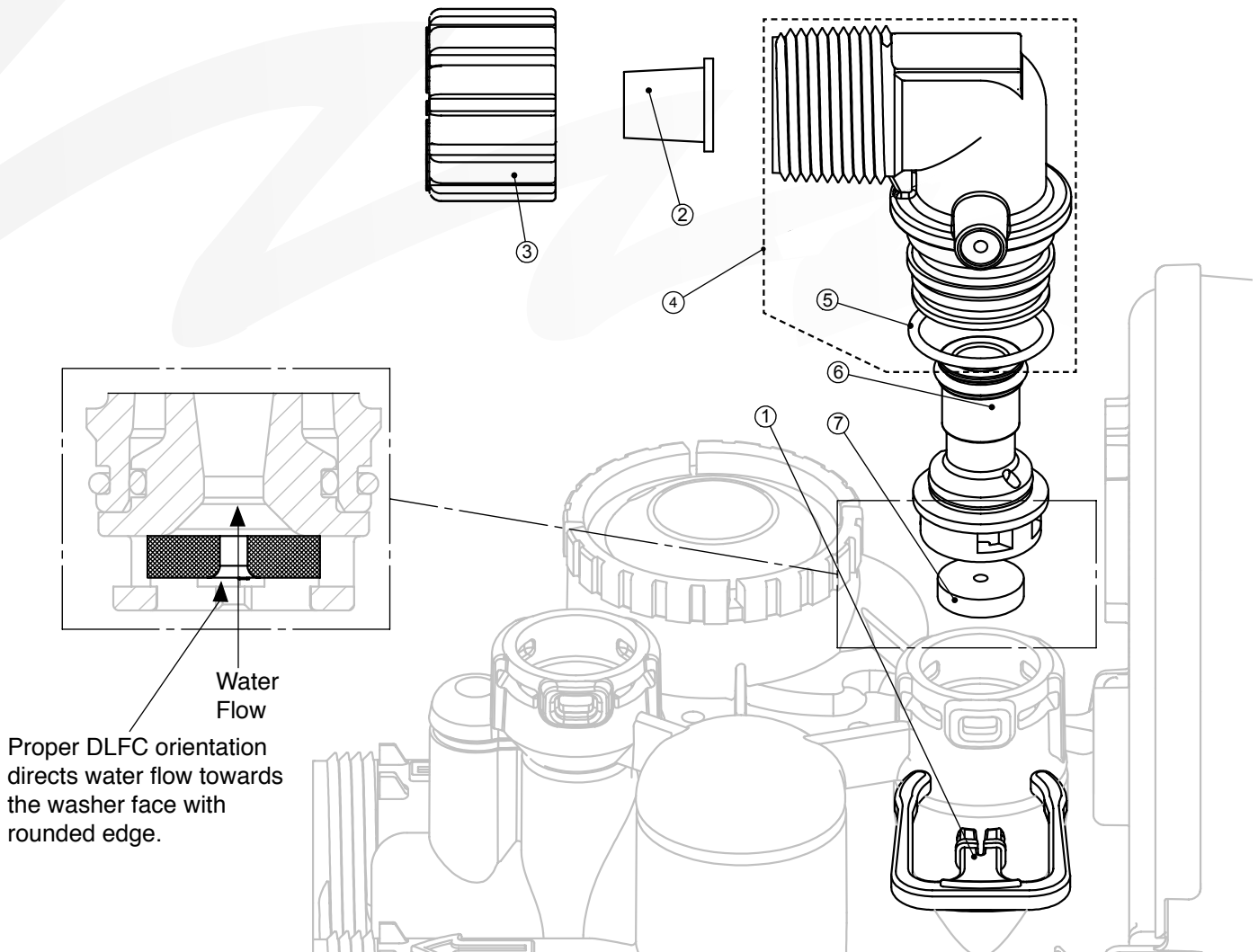

Drain Line - 1"

Drawing No.	Order No.	Description	Quantity
1	H4615	Elbow Locking Clip	1
2*	V3166	WS1 Drain FTG Body 1	1
	V3166-01	FTG Flow Control Body Female 1	
3*	V3167	WS1 Drain FTG Adapter 1	1
4*	V3163	O-ring 019	1
5*	V3150	WS1 Split Ring	1
6*	V3151	WS1 Nut 1" QC	1
7*	V3105	O-ring 215	1
8	V3190-090	WS1 DLFC 9.0 gpm for 1	One DLFC must be used if 1" fitting is used
	V3190-100	WS1 DLFC 10.0 gpm for 1	
	V3190-110	WS1 DLFC 11.0 gpm for 1	
	V3190-130	WS1 DLFC 13.0 gpm for 1	
	V3190-150	WS1 DLFC 15.0 gpm for 1	
	V3190-170	WS1 DLFC 17.0 gpm for 1	
	V3190-200	WS1 DLFC 20.0 gpm for 1	
	V3190-250	WS1 DLFC 25.0 gpm for 1	

*2 through 7 can be ordered as a complete assembly: V3008-02 WS1 FTG DRAIN 1 STRT W/SIL or V3008-04 WS1 FTG DRAIN 1 STRT WO/SIL

* Can be ordered as a set. Order number V3008-02, description: WS1 Drain FTG 1 Straight.

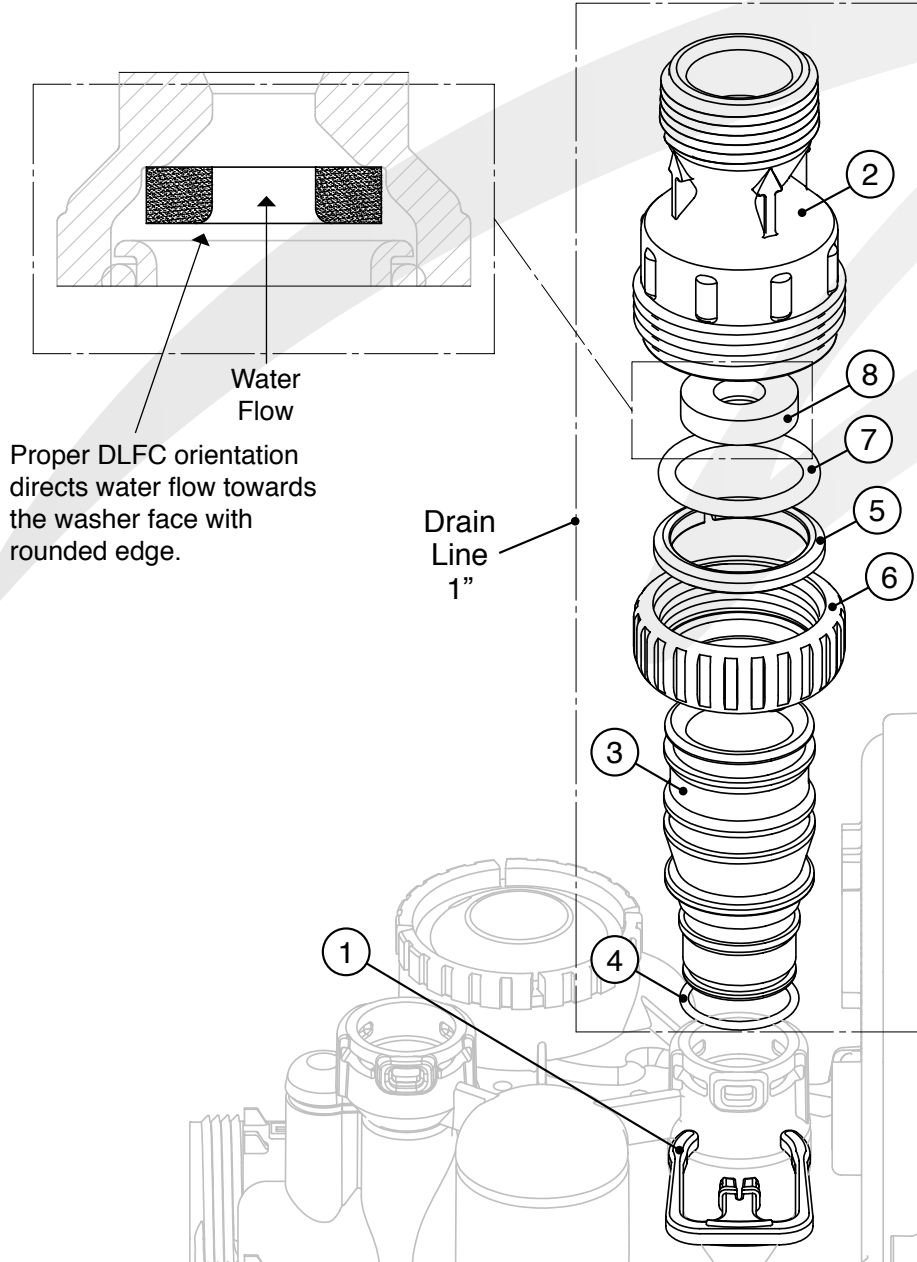

Water Meter, Meter Plug and Mixing Valve

Drawing No.	Order No.	Description	Quantity
1	V3151	WS1 Nut 1" QC	1
2	V3003*	WS1 Meter ASY	1
3	V3118-01	WS1 Turbine ASY	1
4	V3105	O-ring 215	1
5	V3003-01	WS1 Meter Plug ASY	1
6	V3013	Mixing Valve	Optional

*Order number V3003 includes V3118-01 WS1 Turbine ASY and V3105 O-ring 215.

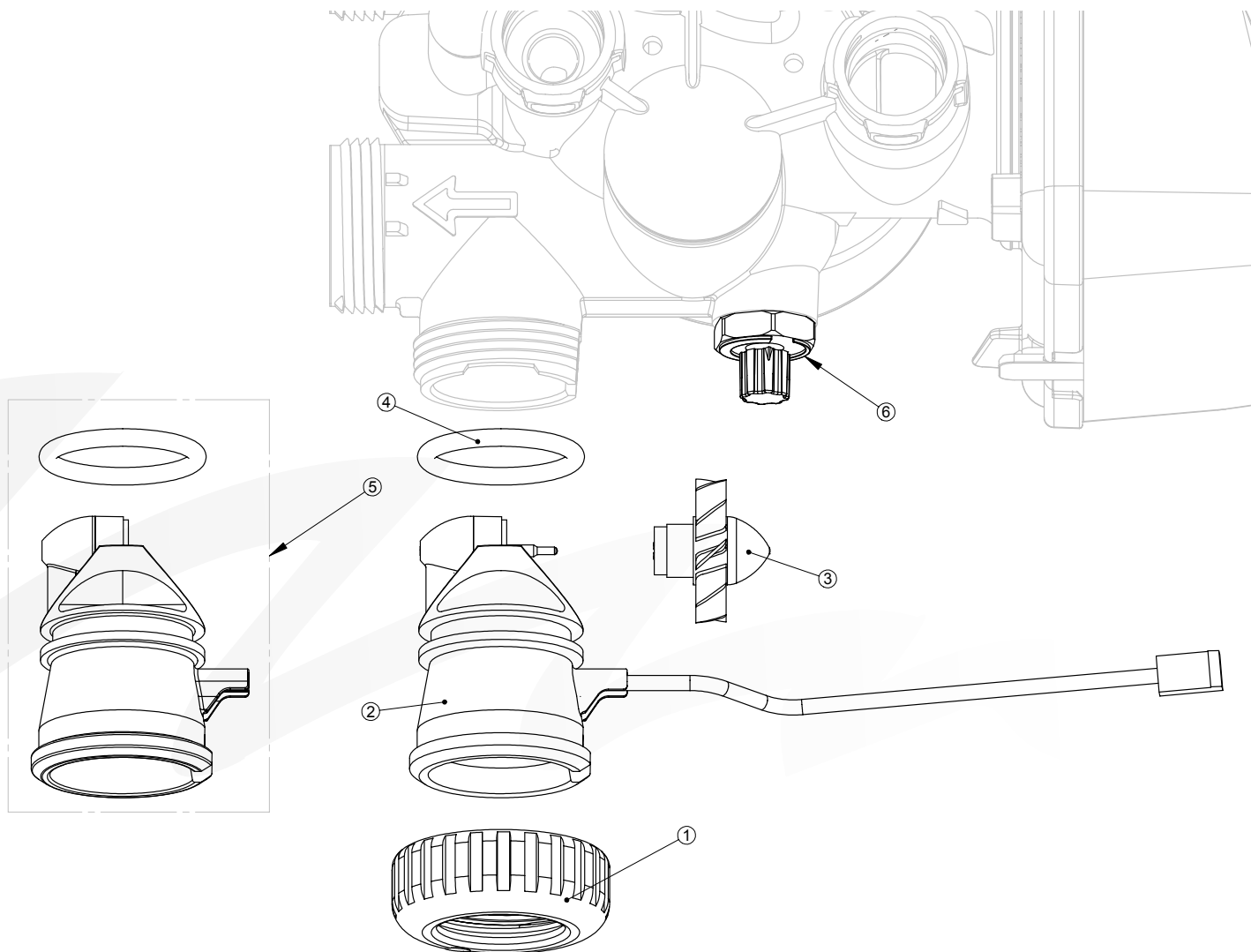

THIS WATER METER SHOULD NOT BE USED AS THE PRIMARY MONITORING DEVICE FOR CRITICAL OR HEALTH EFFECT APPLICATIONS.

NOTE: A water meter is not applicable for a TC control valve.

Installation Fitting Assemblies

Order No: V3007

Description: WS1 Fitting 1" PVC Male NPT Elbow Assembly

Drawing No.	Order No.	Description	Quantity
1	V3151	WS1 NUT 1" QUICK CONNECT	2
2	V3150	WS1 SPLIT RING	2
3	V3105	O-RING 215	2
4	V3149	WS1 FITTING 1 PVC MALE NPT ELBOW	2

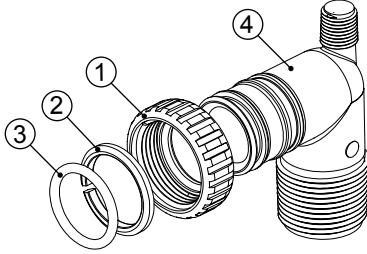

Order No: V3007-01

Description: WS1 Fitting 3/4" & 1" PVC Solvent 90° ASY

Drawing No.	Order No.	Description	Quantity
1	V3151	WS1 NUT 1" QUICK CONNECT	2
2	V3150	WS1 SPLIT RING	2
3	V3105	O-RING 215	2
4	V3189	WS1 FITTING 3/4" & 1" PVC SOLVENT 90	2

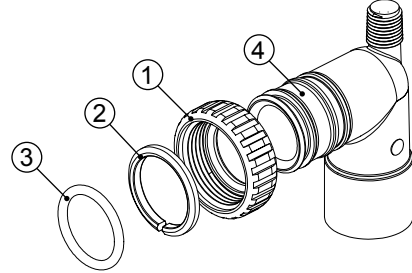

Order No: V3007-02LF

Description: WS1 Fitting 1" Brass Sweat Assembly LF

Drawing No.	Order No.	Description	Quantity
1	V3151	WS1 NUT 1" QUICK CONNECT	2
2	V3150	WS1 SPLIT RING	2
3	V3105	O-RING 215	2
4	V3188-LF	WS1 FITTING 1 BRASS SWEAT ASSEMBLY LF	2

Do not install in California.

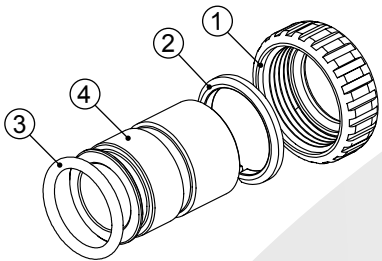

Order No: V3007-03LF

Description: WS1 Fitting 3/4" Brass Sweat Assembly LF

Drawing No.	Order No.	Description	Quantity
1	V3151	WS1 NUT 1" QUICK CONNECT	2
2	V3150	WS1 SPLIT RING	2
3	V3105	O-RING 215	2
4	V3188-01LF	WS1 FITTING 3/4 BRASS SWEAT LF	2

Do not install in California.

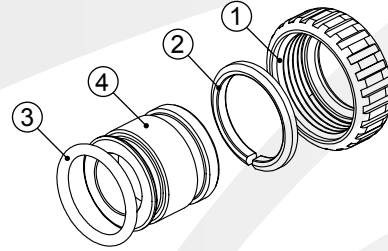

Order No: V3007-04

Description: WS1 Fitting 1" Plastic Male NPT Assembly

Drawing No.	Order No.	Description	Quantity
1	V3151	WS1 NUT 1" QUICK CONNECT	2
2	V3150	WS1 SPLIT RING	2
3	V3105	O-RING 215	2
4	V3164	WS1 FITTING 1" PLASTIC MALE NPT	2

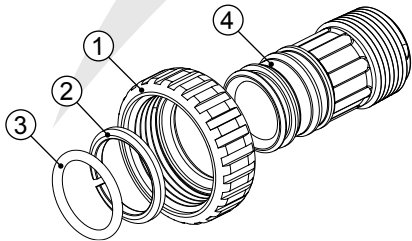

Order No: V3007-05

Description: WS1 Fitting 1-1/4" Plastic Male NPT Assembly

Drawing No.	Order No.	Description	Quantity
1	V3151	WS1 NUT 1" QUICK CONNECT	2
2	V3150	WS1 SPLIT RING	2
3	V3105	O-RING 215	2
4	V3317	WS1 FITTING 1-1/4" PLASTIC MALE NPT	2

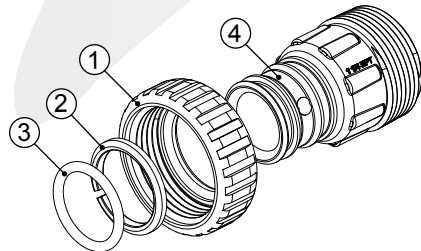

Order No: V3007-06

Description: WS1 Fitting 1" Plastic Male BSPT Assembly

Drawing No.	Order No.	Description	Quantity
1	V3151	WS1 NUT 1" QUICK CONNECT	2
2	V3150	WS1 SPLIT RING	2
3	V3105	O-RING 215	2
4	V3316	WS1 FITTING 1" PLASTIC MALE BSPT	2

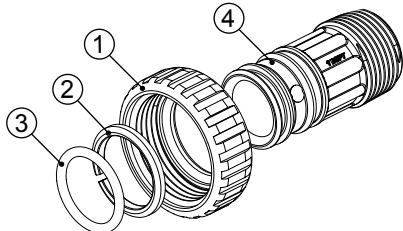

Order No: V3007-07

Description: WS1 Fitting 1-1/4" & 1-1/2" PVC Solvent Assembly

Drawing No.	Order No.	Description	Quantity
1	V3151	WS1 NUT 1" QUICK CONNECT	2
2	V3150	WS1 SPLIT RING	2
3	V3105	O-RING 215	2
4	V3352	WS1 FITTING 1-1/4" & 1-1/2" PVC SOLVENT	2

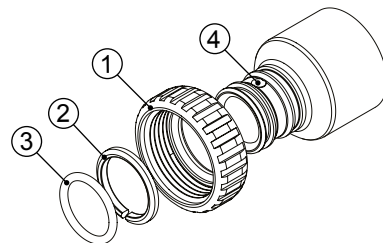

Installation Fitting Assemblies

Order No. V3007-08

Description: WS1 Fitting 1-1/4" Plastic Male BSPT Assembly

Drawing No.	Order No.	Description	Quantity
1	V3151	WS1 NUT 1" QUICK CONNECT	2
2	V3150	WS1 SPLIT RING	2
3	V3105	O-RING 215	2
4	V3361	WS1 FITTING 1-1/4" PLASTIC MALE BSPT	2

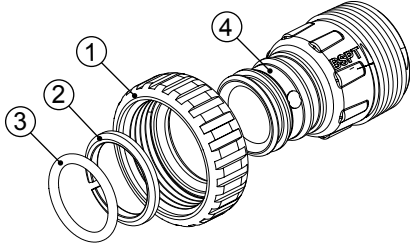

Order No: V3007-09LF

Description: WS1 Fitting 1-1/4" & 1-1/2" Brass Sweat Assembly LF

Drawing No.	Order No.	Description	Quantity
1	V3151	WS1 NUT 1" QUICK CONNECT	2
2	V3150	WS1 SPLIT RING	2
3	V3105	O-RING 215	2
4	V3375-LF	WS1 FITTING 1-1/4" & 1-1/2" BRASS SWEAT LF	2

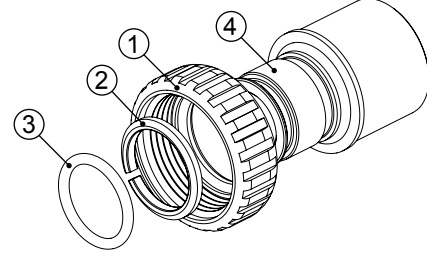

Order No. V3007-12LF

Description: WS1 Fitting 3/4" Brass SharkBite Assembly LF

Drawing No.	Order No.	Description	Quantity
1	V3151	WS1 NUT 1" QUICK CONNECT	2
2	V3150	WS1 SPLIT RING	2
3	V3105	O-RING 215	2
4	V3628-LF	WS1 FTG 3/4 BRASS SHARKBITE LF	2

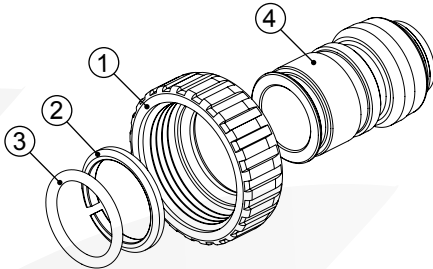

Order No. V3007-13LF

Description: WS1 Fitting 1" Brass SharkBite Assembly LF

Drawing No.	Order No.	Description	Quantity
1	V3151	WS1 NUT 1" QUICK CONNECT	2
2	V3150	WS1 SPLIT RING	2
3	V3105	O-RING 215	2
4	V3629-LF	WS1 FTG 1" BRASS SHARKBITE LF	2

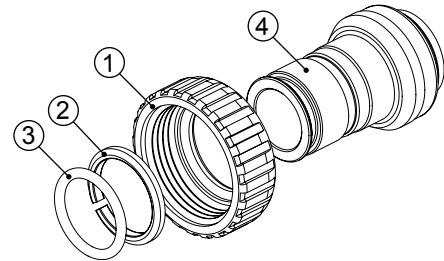

Order No. V3007-14

Description: WS1 Fitting 3/4" Plastic Male BSPT Assembly

Drawing No.	Order No.	Description	Quantity
1	V3151	WS1 NUT 1" QUICK CONNECT	2
2	V3150	WS1 SPLIT RING	2
3	V3105	O-RING 215	2
4	V3594	WS1 FITTING 3/4" PLASTIC MALE BSPT	2

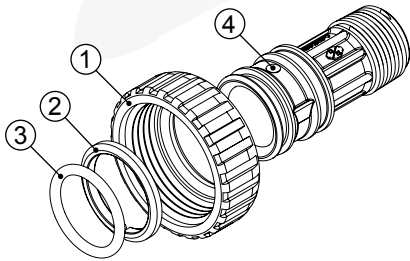

Order No. V3007-15

Description: WS1 FTG 3/4 QC 90 ASY

Drawing No.	Order No.	Description	Quantity
1	V3151	WS1 NUT 1 QC	2
2	V3150	WS1 SPLIT RING	2
3	V3105	O-RING 215	2
4	V3790	WS1 ELBOW 3/4 QC W/STEM	2

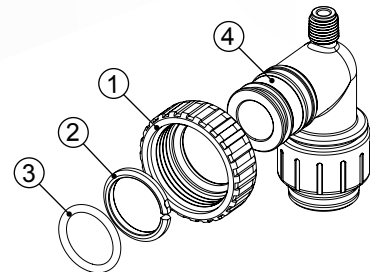

Order No. V3007-16

Description: WS1 Fitting 1" PVC Male BSPT Elbow Assembly

Drawing No.	Order No.	Description	Quantity
1	V3151	WS1 NUT 1" QUICK CONNECT	2
2	V3150	WS1 SPLIT RING	2
3	V3105	O-RING 215	2
4	V3797	WS1 FTG 1" PVC MALE BSPT ELBOW	2

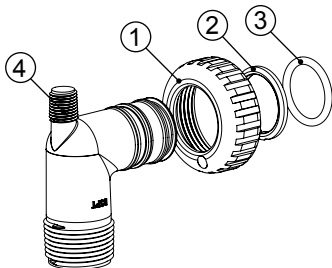

Order No. V3007-17

Description: WS1 FTG 1" JG QC ASY

Drawing No.	Order No.	Description	Quantity
1	V3105	O-RING 215	2
2	V3150	WS1 SPLIT RING	2
3	V3151	WS1 NUT 1 QC	2
4	V4045	WS1 FTG 1 INCH QC	2

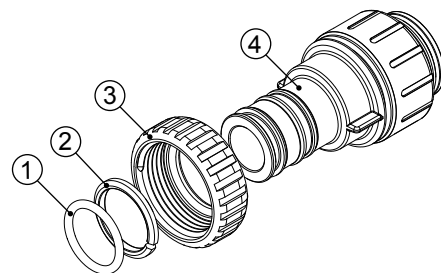

Bypass Valve

Drawing No.	Order No.	Description	Quantity
1	V3151	WS1 Nut 1" Quick Connect	2
2	V3150	WS1 Split Ring	2
3	V3105	O-Ring 215	2
4	V3145	WS1 Bypass 1" Rotor	2
5	V3146	WS1 Bypass Cap	2
6	V3147	WS1 Bypass Handle	2
7	V3148	WS1 Bypass Rotor Seal Retainer	2
8	V3152	O-ring 135	2
9	V3155	O-ring 112	2
10	V3156	O-ring 214	2

(Not Shown) Order No. V3191-01, Description: WS1 Bypass Vertical Adapter Assembly

Order No.	Description	Quantity
V3151	WS1 Nut 1" Quick Connect	2
V3150	WS1 Split Ring	2
V3105	O-Ring 215	2
V3191	WS1 Bypass Vertical Adapter	2

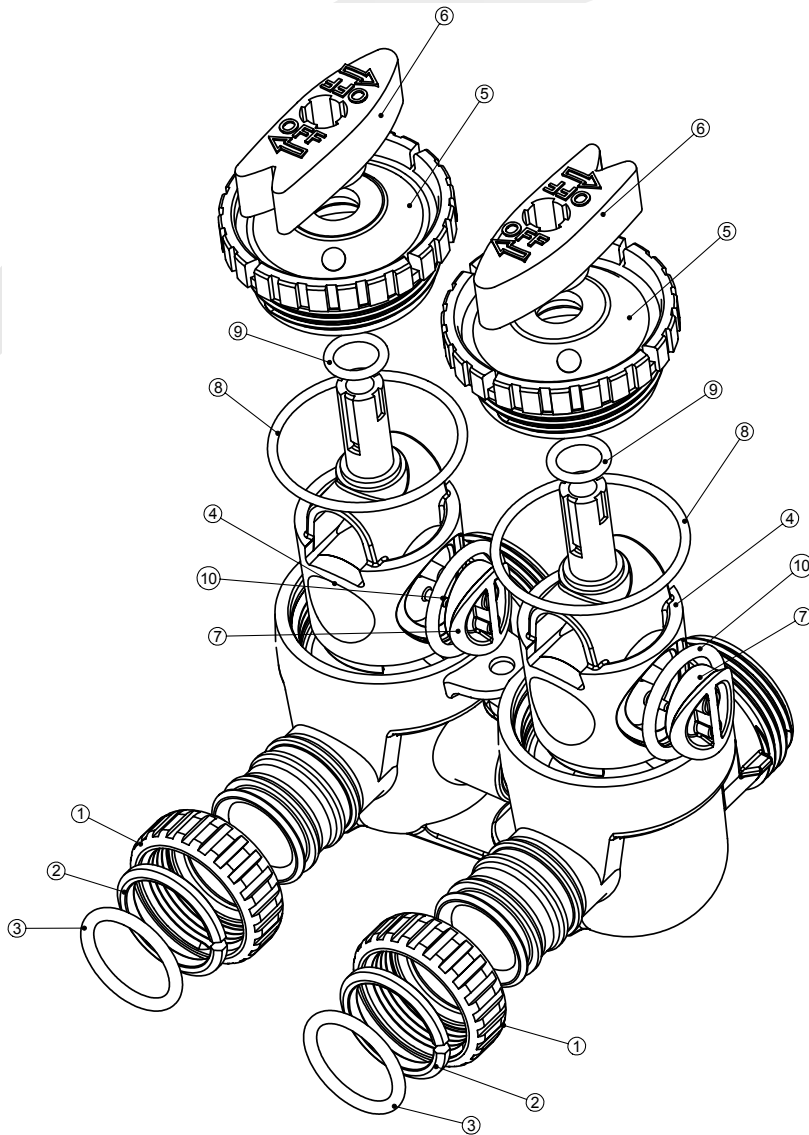

flow diagram...service

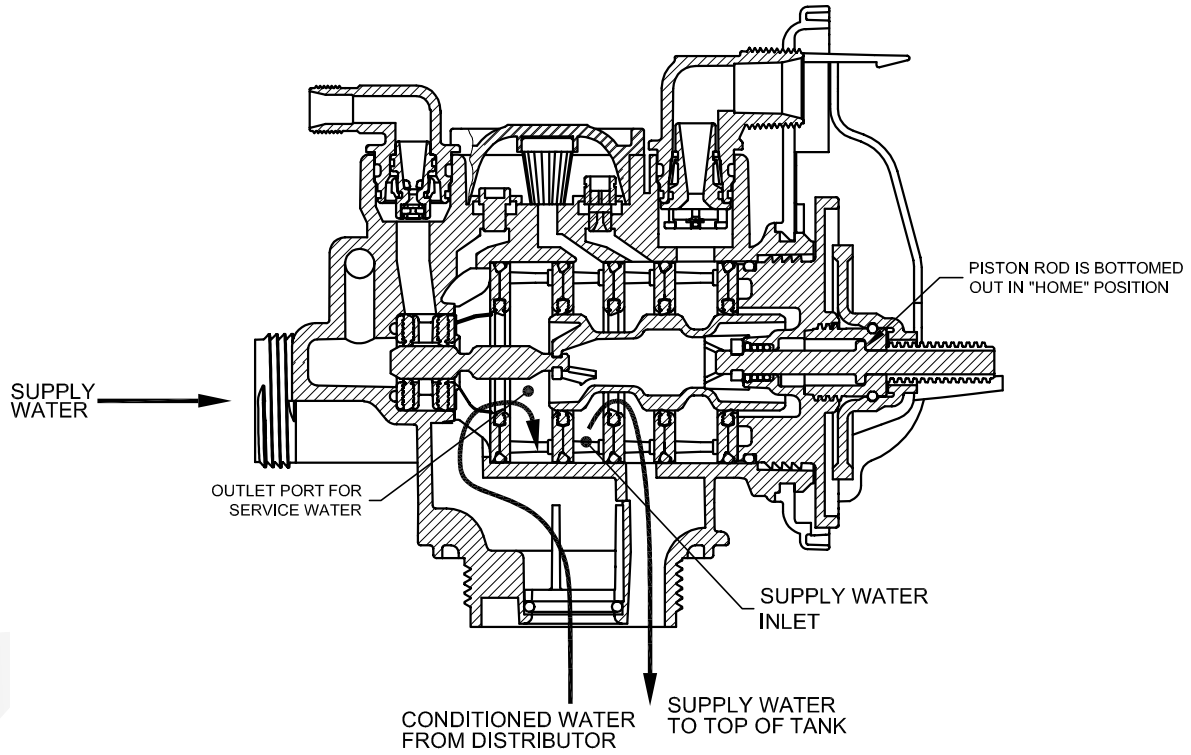

flow diagram...backwash

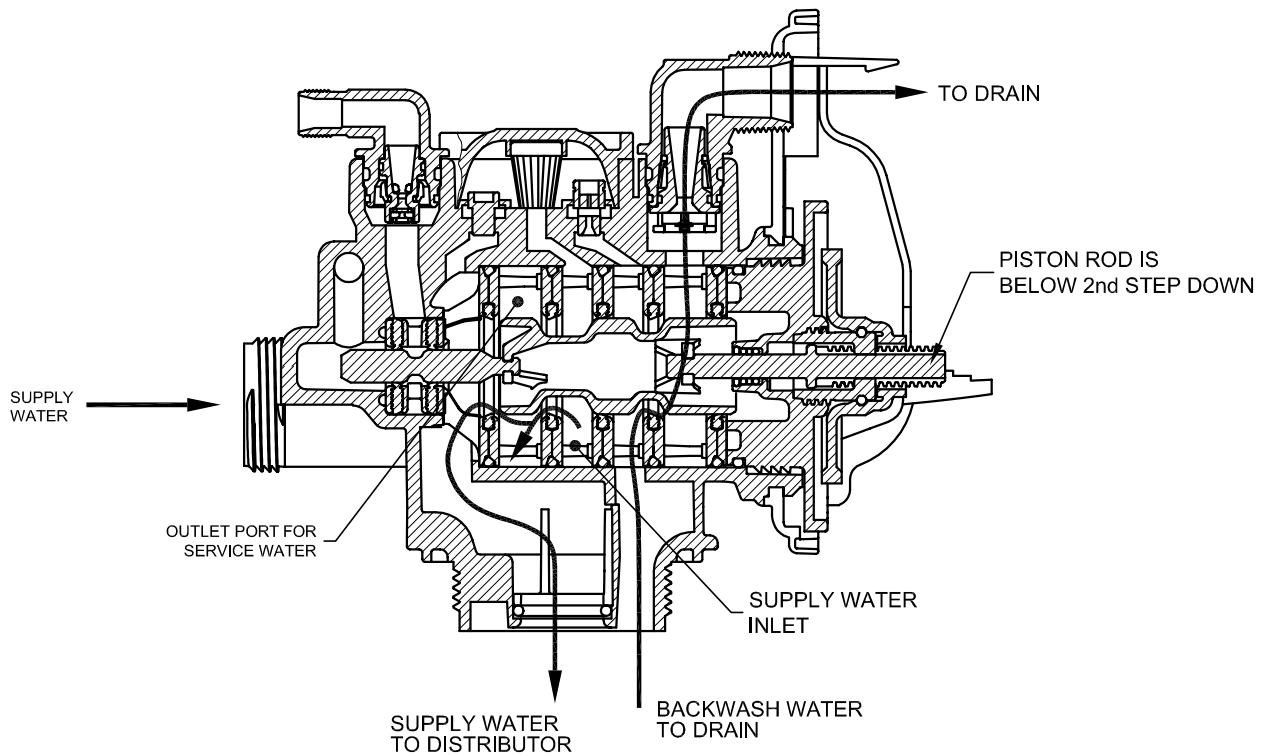

flow diagram...downflow brine

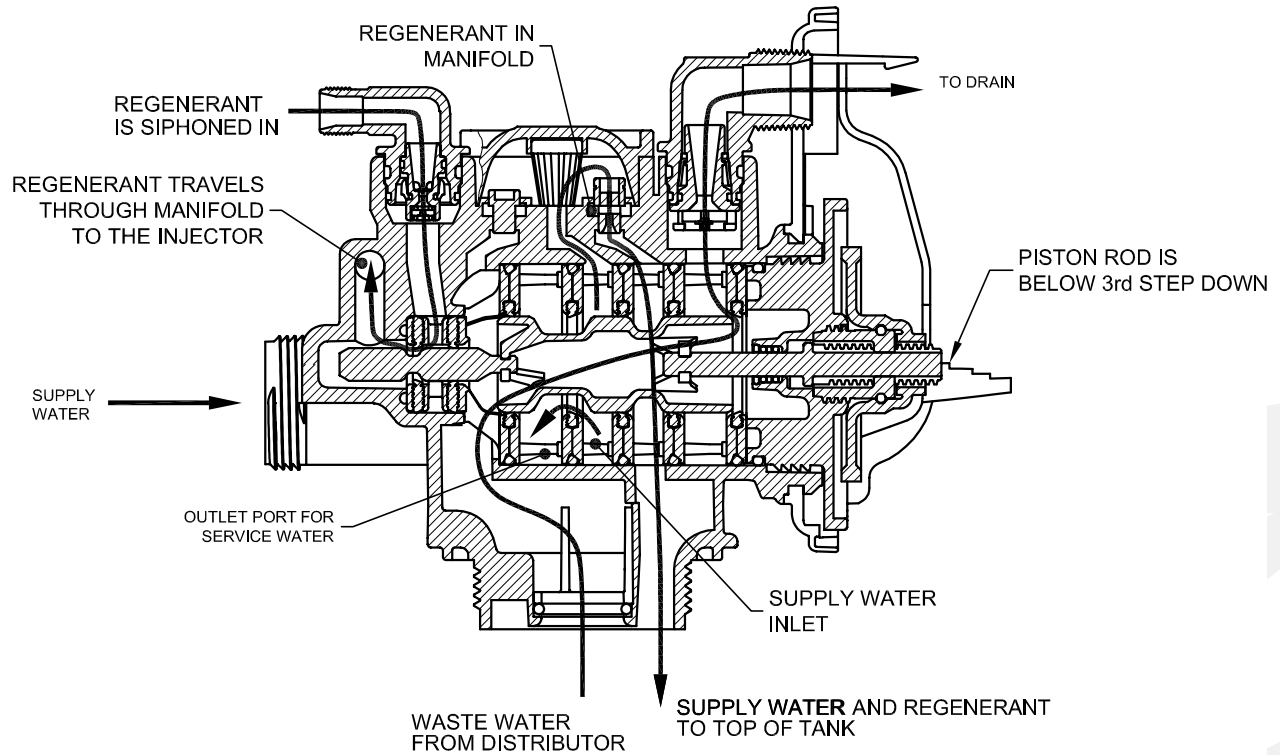

Upflow not applicable for EE, EI, or TC WS1 and WS1.25 control valves.

flow diagram...upflow brine

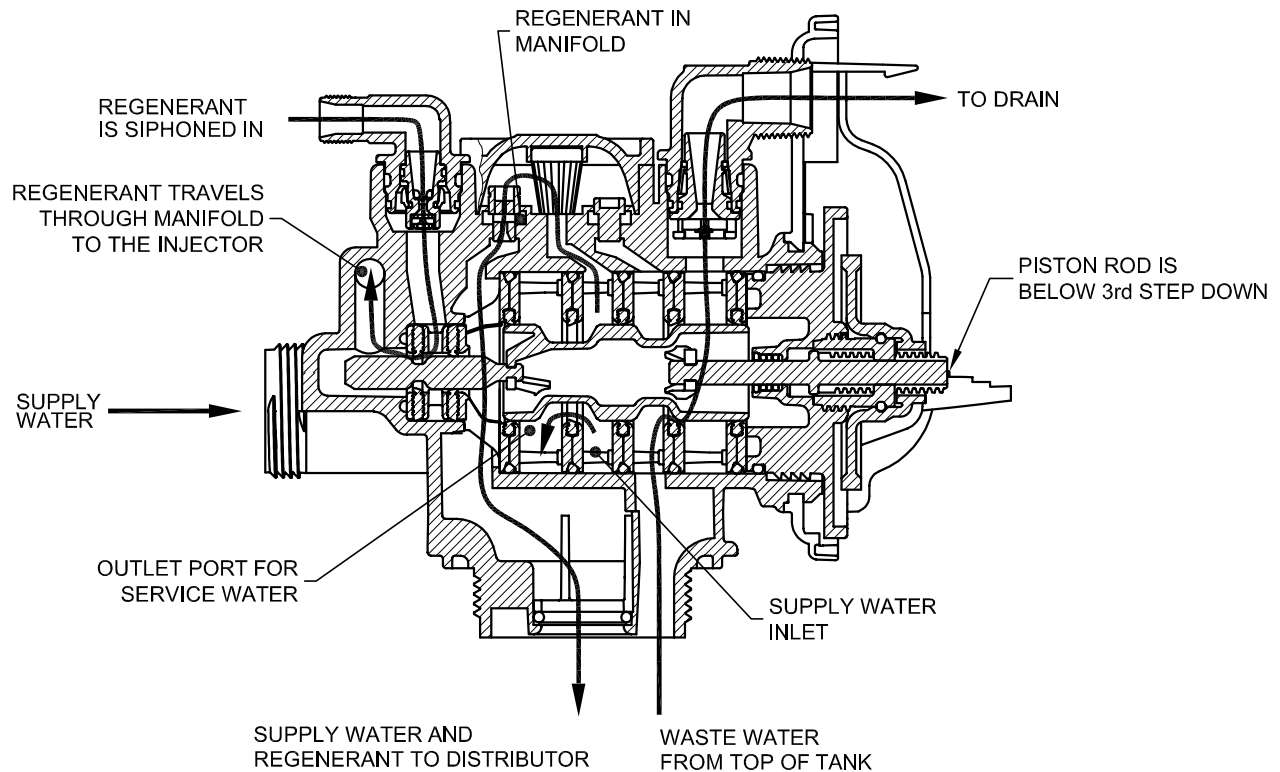

flow diagram...rinse

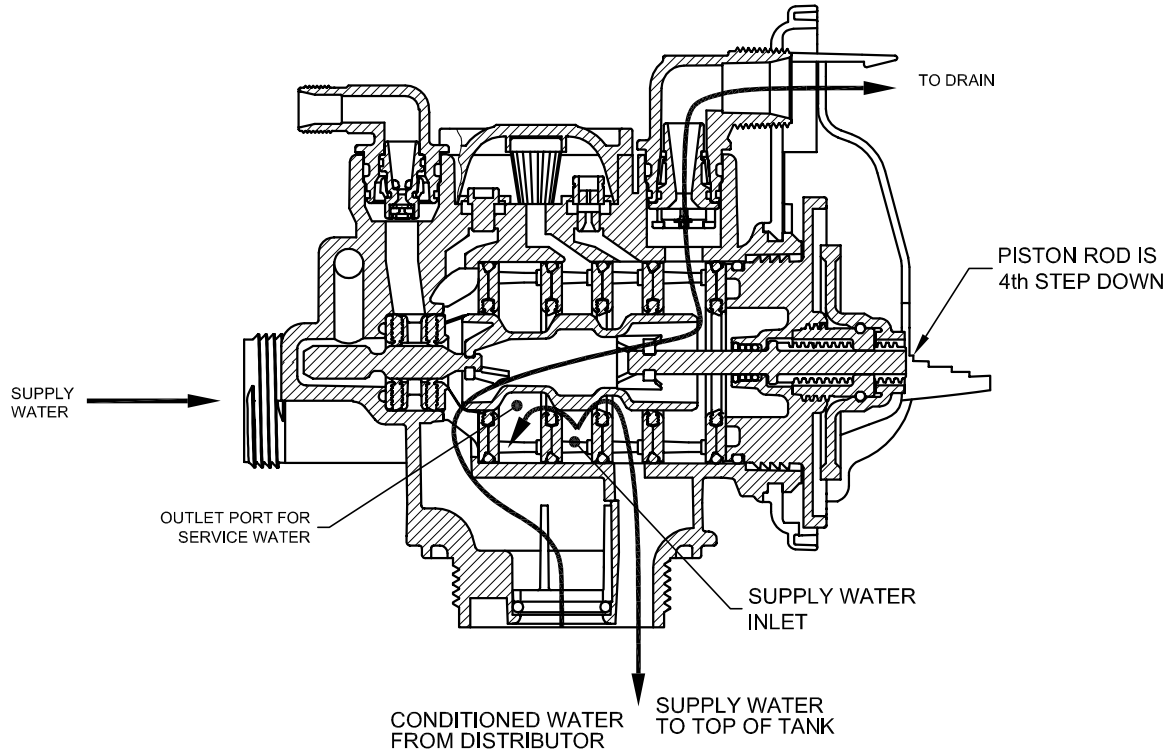

flow diagram...fill

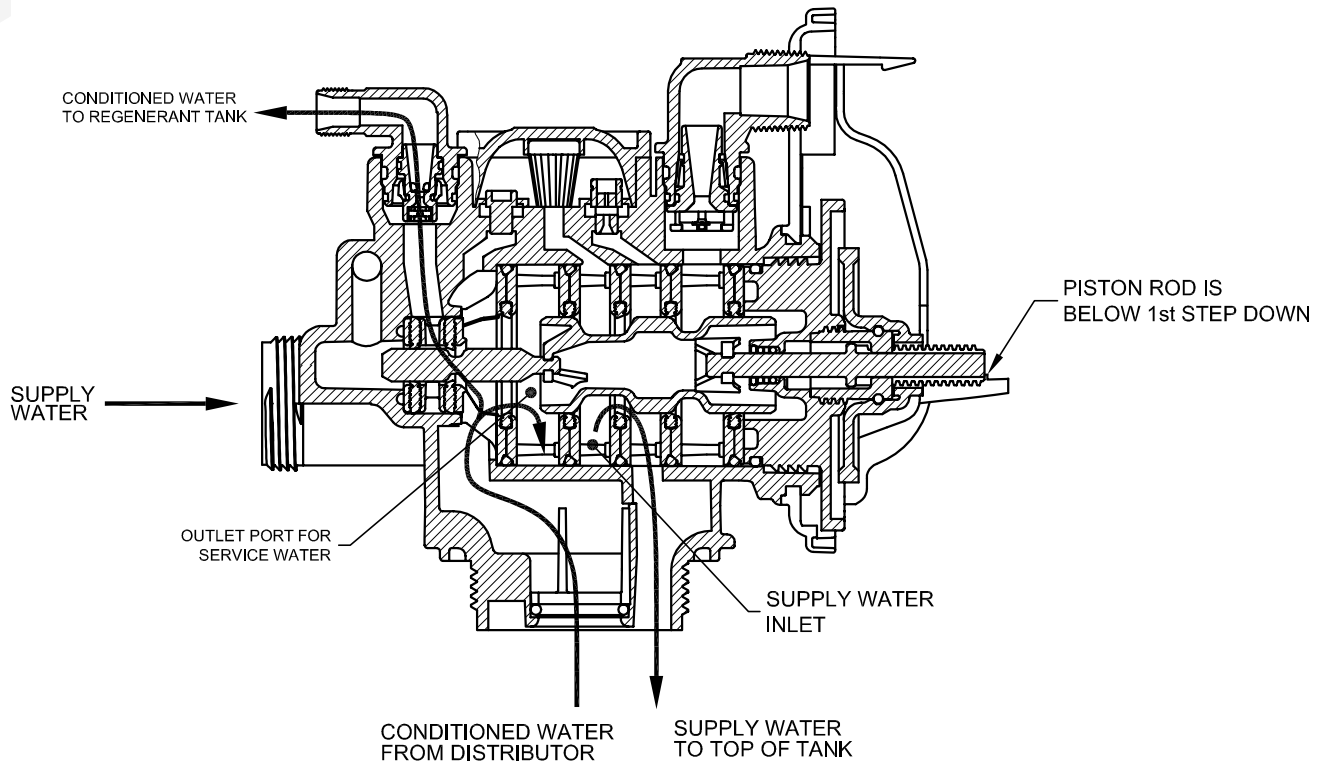

WS1 Service Spanner Wrench (Order No. V3193-02)

Although no tools are necessary to assemble or disassemble the valve, the WS1 wrench (shown in various positions on the valve) may be purchased to aid in assembly or disassembly.

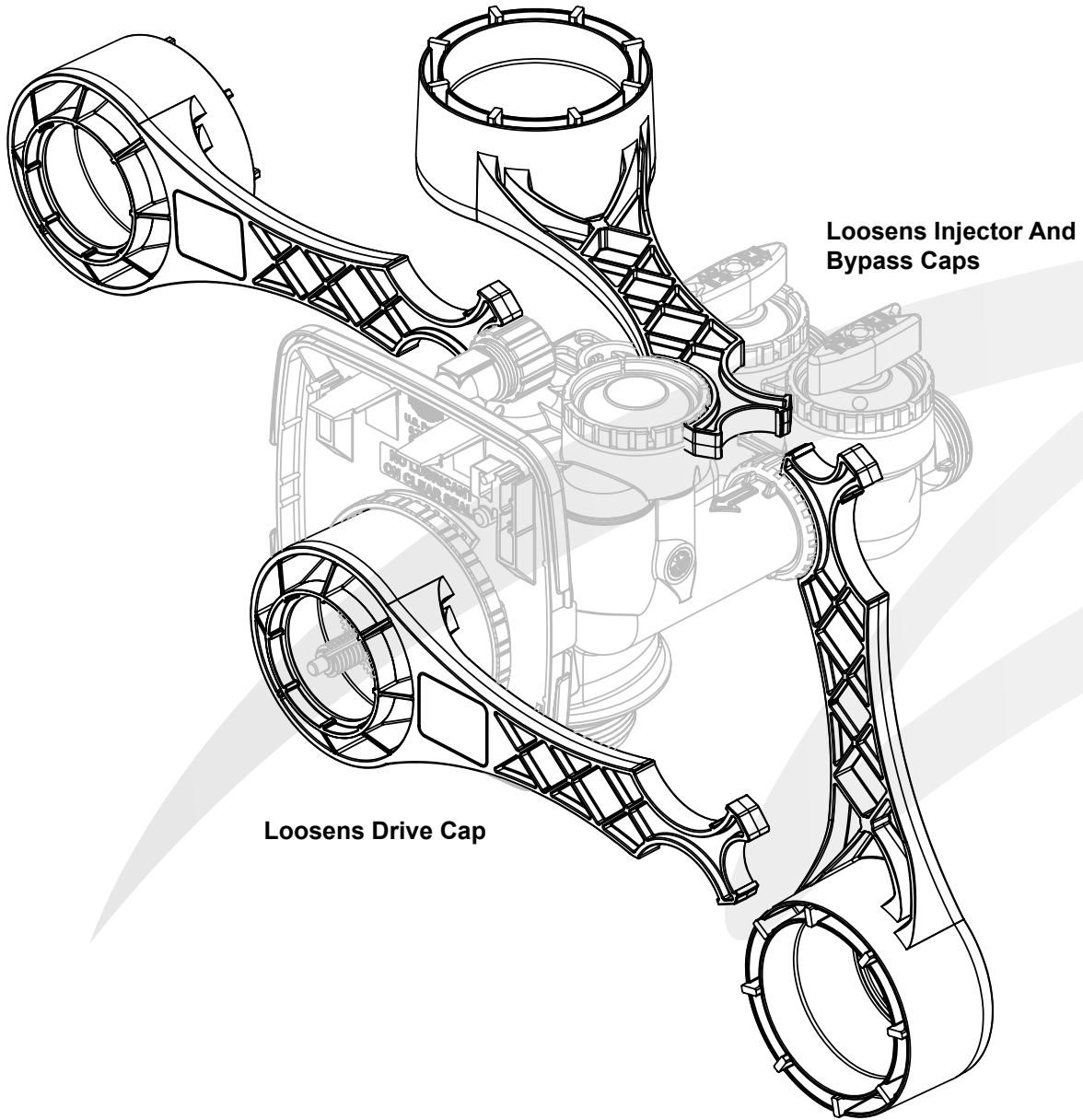

Introduction

This manual is about a control valve to be used on water softeners or water filters. The manual is designed to aid water treatment equipment manufacturers in the selection of the various control valve options. Information in this manual is different than what is needed for installation and servicing of a particular water treatment system. This manual is not intended to be used as a manual for a complete water softener or filter. Certain parts of the manual will serve as aids to manufacturers in the writing and layout of the manuals for installers and service personnel.

General Warnings *(Must appear in OEM's manual)*

The following general warnings and the specifications in Table 1 must appear in the OEM's System Manual.

The control valve, fittings and/or bypass are designed to accommodate minor plumbing misalignments but are not designed to support the weight of a system or the plumbing.

HYDROCARBONS SUCH AS KEROSENE, BENZENE, GASOLINE, ETC., MAY DAMAGE PRODUCTS THAT CONTAIN O-RINGS OR PLASTIC COMPONENTS. EXPOSURE TO SUCH HYDROCARBONS MAY CAUSE THE PRODUCTS TO LEAK. DO NOT USE THE PRODUCT(S) CONTAINED IN THIS DOCUMENT ON WATER SUPPLIES THAT CONTAIN HYDROCARBONS SUCH AS KEROSENE, BENZENE, GASOLINE, ETC.

THIS WATER METER SHOULD NOT BE USED AS THE PRIMARY MONITORING DEVICE FOR CRITICAL OR HEALTH EFFECT APPLICATIONS

Do not use Vaseline, oils, other hydrocarbon lubricants or spray silicone anywhere. A silicone lubricant may be used on black o-rings but is not necessary.

The nuts and caps are designed to be unscrewed or tightened by hand or with the special plastic wrench. If necessary a pliers can be used to unscrew the nut or cap. Do not use a pipe wrench to tighten or loosen nuts or caps. Do not place a screwdriver in the slots on caps and/or tap with a hammer.

Do not use pipe dope or other sealants on threads. Use Teflon tape on the threaded inlet, outlet and drain fittings. Teflon tape is not necessary on the nut connection or caps because of o-ring seals.

After completing any valve maintenance involving the drive assembly or the drive cap assembly and pistons unplug power source jack from the printed circuit board (black wire) and plug back in or:

- For valves that use a TC circuit board (three buttons) press and hold SET and DOWN buttons for 3 seconds. The cover button may have other names like "SET HOUR", "CLOCK" or "SET CLOCK" but the circuit board is labeled with SET.
- For all other valves press and hold NEXT and REGEN buttons for 3 seconds.

This resets the electronics and establishes the service piston position. The display should flash all wording, then flash the software version and then reset the valve to the service position.

All plumbing should be done in accordance with local plumbing codes. The pipe size for the drain line should be a minimum of ½". Backwash flow rates in excess of 7 gpm (26.5 lpm) or length in excess of 20' (6.1m) require ¾" drain line.

Solder joints near the drain must be done prior to connecting the drain line flow control fitting. Leave at least 6" between the drain line control fitting and solder joints when soldering pipes that are connected on the drain line control fitting. Failure to do this could cause interior damage to the drain line flow control fitting.

When assembling the installation fitting package (inlet and outlet), connect the fitting to the plumbing system first and then attach the nut, split ring and o-ring. Heat from soldering or solvent cements may damage the nut, split ring or o-ring. Solder joints should be cool and solvent cements should be set before installing the nut, split ring and o-ring. Avoid getting primer and solvent cement on any part of the o-rings, split rings, bypass valve or control valve.

Plug into an electrical outlet. Note: All electrical connections must be connected according to local codes. (Be certain the outlet is uninterrupted.)

Install grounding strap on metal pipes.

This glass filled Noryl¹ (or equivalent) fully automatic control valve is designed as the primary control center to direct and regulate all cycles of a water softener or filter. When the WS1 or WS1.25 control valve is manufactured as a softener, the control valve can be ordered to perform downflow or upflow regeneration. When the WS1 or WS1.25 control valve is set up as a filter, the control valve can be set to perform downflow regeneration or simply backwash. The control valve can be set to regenerate on demand (consumption of a predetermined amount of water) and/or as a time clock (passage of a particular number of days). The control valve can be set so that a softener can meet the Water Quality Association (WQA) Standard S100 or NSF/ANSI Standard 44 efficiency rating.

It is not recommended to change control valves from downflow to upflow brining or vice versa in the field. The valve bodies for downflow and upflow are unique to the regeneration type and should not be interchanged. A mismatch of valve body and regeneration piston will result in hard water bypass during service.

The control valve is compatible with a variety of regenerants and resin cleaners. The control valve is capable of routing the flow of water in the necessary paths to regenerate or backwash water treatment systems. The injector regulates the flow of brine or other regenerants. The control valve regulates the flow rates for backwashing, rinsing, and the replenishing of treated water into a regenerant tank, when applicable.

The control valve uses no traditional fasteners (e.g. screws); instead clips, threaded caps and nuts and snap type latches are used. Caps and nuts only need to be firmly hand tightened because radial seals are used. Tools required to service the valve include one small blade screw driver, one large blade screw driver, pliers and a pair of hands. A plastic wrench is available which eliminates the need for screwdrivers and pliers. Disassembly for servicing takes much less time than comparable products currently on the market. Control valve installation is made easy because the distributor tube can be cut ½” above to ½” below the top of tank thread. The distributor tube is held in place by an o-ring seal and the control valve also has a bayonet lock feature for upper distributor baskets.

The AC adapter comes with a 15 foot power cord and is designed for use with the control valve. The AC adapter is for dry location use only. The control valve remembers all settings until the battery power is depleted if the power goes out. After the battery power is depleted, the only item that needs to be reset is the time of day; other values are permanently stored in the nonvolatile memory. The control valve battery is not rechargeable but is replaceable.

¹Noryl is a trademark of Sabic

Table 1
Specifications which must be included in OEM's Manual

Minimum/Maximum Operating Pressures	20 psi (138 kPa or 1.4 bar) -125 psi (862 kPa or 8.6 bar)
Minimum/Maximum Operating Temperatures	40°F (4°C) - 110°F (43°C)
Power Adapter: Supply Voltage Supply Frequency Output Voltage Output Current	See Drawings and Part Numbers page 1 for data
No user serviceable parts are on the PC board, the motor, or the power adapter. The means of disconnection from the main power supply is by unplugging the power adapter from the wall.	

Table 2 contains a summary of specifications for the control valve and bypass valve.

Table 2
Quick Reference Specifications

Service flow rate 1" (includes bypass and meter)	27 gpm (102.2 lpm, 6.1 m ³ /h) @15 psig (103 kPa) drop
Backwash flow rate 1" (includes bypass)	27 gpm (102.2 lpm, 6.1 m ³ /h) @25 psig (172 kPa) drop
Service flow rate 1.25" (includes meter)*	34 gpm (128.7 lpm, 7.7 m ³ /h) @15 psig (103 kPa) drop
Service flow rate 1.25" (includes bypass and meter)*	32 gpm (121.1 lpm, 7.3 m ³ /h) @15 psig (103 kPa) drop
Backwash flow rate 1.25"*	32 gpm (121.1 lpm, 7.3 m ³ /h) @25 psig (172 kPa) drop
Backwash flow rate 1.25" (includes bypass)*	30 gpm (113.5 lpm, 6.8 m ³ /h) @25 psig (172 kPa) drop
Minimum/Maximum Operating Pressures	20 psi (138 kPa) -125 psi (862 kPa)
Minimum/Maximum Operating Temperatures	40°F (4°C) - 110°F (43°C)
Power Adapter: Supply Voltage Supply Frequency Output Voltage Output Current	See Drawings and Part Numbers page 1
Regenerant Refill Rate	0.5 gpm (1.9 lpm)
Injectors	See Drawings and Part Numbers pages 3c-3f
Drain Line Flow Controls	See General Information page 5
Inlet / Outlet Fitting Options	See Drawings and Part Numbers pages 8a-8b
Distributor Tube Opening WS1 Valve	1.05" outside diameter (¾" NPS)
Distributor Tube Opening WS1.25 Valve*	1.32" outside diameter (1" NPS)
	32 mm outside diameter
Tank Thread	2½" - 8 NPSM
Control Valve Weight	4.5 lbs. 2.0 kg
PC Board Memory	Nonvolatile EEPROM (electrically erasable programmable read only memory)
Compatible with regenerants/chemicals	Sodium chloride, potassium chloride, potassium permanganate, sodium bisulfite, chlorine and chloramines

*Not applicable for control valves which use quick connect tank adapters.

The WS1 & WS1.25 control valves consist of the following components:

- | | |
|--|---|
| 1. Drive Assembly | 6. Drain Line Flow Control and Fitting Assembly |
| 2. Drive Cap Assembly, Main Piston and Regenerant Piston | 7. Water Meter or Meter Plug |
| 3. Spacer Stack Assembly | 8. Mixing Valve (optional) |
| 4. Injector Cap, Screen, Injector Plug and Injector | 9. Installation Fitting Assemblies |
| 5. Refill Flow Control Assembly or Refill Port Plug | 10. Bypass Valve (optional) |

Note: The WS1 & WS1.25 share many of the same components. Refer to page 13 for control valve identification.

Drive Assembly

The drive assembly consists of the following parts:

- Drive Bracket
- Printed Circuit (PC) Board
- Motor
- Drive Gears
- Drive Gear Cover

The drive bracket holds the PC board, the motor, the drive gears and the drive gear cover in place.

The PC board receives and retains information, displays the information, determines when to regenerate and initiates regeneration. The display shows different types of information in the initial system set up (for softeners or filters), installer display settings, diagnostics, valve history or user display settings.

The PC board powers the motor. The PC board's two-prong jack connects wires to the direct current (DC) motor. The motor is held in place on the drive bracket by a spring-loaded clip and a small bulge in the plastic, which fits in one of the slots on the motor housing. The motor turns drive gears that drive the piston to cycle positions for backwashing, regeneration, rinsing, refill or service. The motor is fully reversible (turns both ways) and changes direction of rotation to change the direction of piston motion. The motor is easily replaced if necessary.

There are three drive gears held in place by the drive gear cover. All three drive gears are the same size. A reflective coating is applied to the gears. As the center drive gear turns a light shines on the coating and a light sensing diode determines if a light pulse was returned. The PC board counts the pulses and determines when to stop driving the motor.

Drive Cap Assembly, Main Piston and Regenerant Piston

The drive gears turn the main gear of the drive cap assembly, which moves the piston. The screw-driven, horizontally moving piston stops at specific positions to direct the flow of water to backwash, regenerate, rinse or refill. The PC board determines the position of the piston by counting pulses produced when the piston is moved. An optical sensor looking at one of the reduction drive gears generates these pulses. Each cycle position is defined by a number of pulses. The counter is zeroed each time the valve goes to the service position. The PC board finds the service position by noting the increase in current delivered to the motor when the mechanical stop at the service position is reached. This method of controlling piston position allows for greater flexibility and requires no switches or cams (U.S. Patent 6444127).

One of four main pistons is always used:

1. A 1.25" diameter downflow piston is used when the WS1 control valve is used as a downflow softener, regenerating filter or non-regenerating filter.
2. A 1.25" diameter upflow piston is used when the WS1 control valve is used as an upflow softener. Upflow option not applicable for EE, EI, or TC WS1 control valves.
3. A 1.5" diameter downflow piston is used when the WS1.25 control valve is used as a downflow softener, regenerating filter or non-regenerating filter.
4. A 1.5" diameter upflow piston is used when the WS1.25 control valve is used as an upflow softener. Upflow option not applicable for EE, EI or TC WS1.25 control valves.

If the control valve is used as a softener or a regenerating filter, a regenerant piston must be attached to the main piston. If the control valve is to be used on a system that does not require a regenerant to be added, the regenerant piston must be removed.

Spacer Stack Assembly

The spacer stack assembly provides the necessary flow passage for water during the different cycles. The all-plastic spacer stack assembly (U.S. Patent 6402944) is a one-piece design which allows the stack to be removed using your fingers.

The exterior of the stack is sealed against the body bore with self lubricating EPDM o-rings, while the interior surface is sealed against the piston using slippery self cleaning directional (one-way) silicone lip seals. The lip seals are clear in color and have a special slippery coating so that the piston does not need to be lubricated.

Injector Cap, Screen, Injector Plug and Injector

The screen, injector and/or injector plug(s) are installed under the injector cap in an easy to access location on top of the valve. The injector cap contains four slots so no water accumulates in the cap. The injector cap is designed to be hand tightened.

Under the injector cap there is an easy to clean removable screen to prevent fouling of the injector. There are two holes under the injector cap labeled "DN" and "UP". The holes will be filled with a plug or an injector.

The plug (Order # V3010-1Z) prevents water from traveling a certain pathway. The injector lets water pass through the pathway. The self-priming injector increases the velocity of the water, creating a zone of negative pressure that draws in the concentrated liquid regenerant, such as sodium chloride (brine), potassium permanganate, etc. The regenerant blends with the stream of water, which passes through the media to regenerate the bed.

The injector provides a consistent regenerant/water mixture ratio over the entire operating pressure range of the control valve. The injector provides good performance in a variety of applications, which may involve elevated drain lines and long regenerant draw lengths. Injectors are chosen by knowing the type, amount, and regenerant flow rate for a particular type of media. Guidelines can be found in the media manufacturer's literature. The color coded injectors give different regenerant draw, slow rinse and total flow rates over the pressure range. See Drawings and Part Numbers page 6 for color codings, and injector graphs (pages 7-10) for total, slow rinse and draw flow rates.

The control valve has been manufactured to be one of the following:

- regeneration downflow (for softeners or regenerating filters install injector in DN location, plug in UP location)
- regeneration upflow (upflow option is for softeners only, which are not EE, EI, or TC control valves, install injector in UP location, plug in other hole location)
- no regenerant (both the DN and UP holes have injector plugs installed) and plug installed for the refill elbow

NOTE: It is not recommended to field convert valves from upflow to downflow and vice versa. Separate areas in the valve supply water to the injector for upflow and downflow valves.

Refill Flow Control Assembly or Refill Port Plug

The refill flow control assembly consists of a refill flow elbow, refill flow control retainer assembly, refill flow control, polytube insert and nut assembly. The refill flow control retainer fits in the refill elbow. The refill flow control retainer houses the refill flow control which controls the flow rate when the regenerant tank is being refilled. The refill flow control is a flexible washer-like part with a small orifice and a precision molded contour that delivers a steady 0.5 gpm regenerant tank refill rate at varying inlet pressures. Refill is accomplished with treated water.

The refill flow control assembly is installed in an easy to access refill elbow located on top of the control valve. The refill flow control assembly is attached to the control valve with a locking clip. The locking clip allows the elbow to rotate 270 degrees so the outlet can be orientated towards the regenerant tank.

The control valve has a standard refill elbow to which a 3/8" flexible tube can be connected. An optional elbow can be ordered which accommodates a 1/2" flexible tube for a high regenerant draw rate situation (G injectors and larger). Both elbows use the same refill flow control and retainer.

If the control valve is to be used as a non-regenerant filter control valve, the refill elbow is removed and replaced with a refill port plug P/N V3195-01.

Drain Line Flow Control and Fitting Assembly

The drain line flow control assembly includes a drain line flow control and a fitting. The drain line flow control allows proper media bed expansion by regulating the flow rate to the drain. The drain line flow control is a flexible washer-like part with an orifice and a precision molded contour. The flow rates are within $\pm 10\%$ over the pressure range of 20 psi to 125 psi (1.4 bar to 8.6 bar). See table for flow rate information.

Drain Line Flow Control and Fitting Assembly Information

Drain Line Fitting	Drain Line Flow Control Order No.	Number on Drain Line Flow Control	Backwash Flow Rate (gpm)	Backwash Flow Rate (lpm)
3/4"	V3162-007	007	0.7	2.6
3/4"	V3162-010	010	1.0	3.8
3/4"	V3162-013	013	1.3	4.9
3/4"	V3162-017	017	1.7	6.4
3/4"	V3162-022	022	2.2	8.3
3/4"	V3162-027	027	2.7	10.2
3/4"	V3162-032	032	3.2	12.1
3/4"	V3162-042	042	4.2	15.9
3/4"	V3162-053	053	5.3	20.1
3/4"	V3162-065	065	6.5	24.6
3/4"	V3162-075	075	7.5	28.4
3/4"	V3162-090	090	9.0	34.1
3/4"	V3162-100	100	10.0	37.9
1"	V3190-090	090	9.0	34.1
1"	V3190-100	100	10.0	37.9
1"	V3190-110	110	11	41.6
1"	V3190-130	130	13	49.2
1"	V3190-150	150	15	56.8
1"	V3190-170	170	17	64.3
1"	V3190-200	200	20	75.7
1"	V3190-250	250	25	94.6

The drain line flow control and fitting are located on top of the control valve and replaceable without the use of special tools.

The drain line flow control can be installed in the standard 3/4" drain line elbow, which accommodates 5/8" polytube or 3/4" NPT drain line connections. The optional nut and polytube insert for the 3/4" drain line elbow is designed for use with flexible polytube only. The 3/4" drain line elbow can be rotated 180 degrees so the outlet can be orientated to the nearest drain. The same retainer is used for all drain line flow controls for the 3/4" fitting. Drain line flow controls designed for the 3/4" fitting are available for flow rates ranging from 0.7 to 10 gpm (2.6 to 37.9 lpm).

An optional 1" straight drain line fitting is available to accommodate drain line flow rates ranging from 9 to 25 gpm (34.1 to 94.6 lpm). This fitting is straight but still connects to the control valve using the same locking clip. The drain line flow control is located between two fitted parts (i.e. the fitting acts as the retainer). The nut is unscrewed to access the drain line flow control.

Water Meter or Meter Plug

TC control valves do not use a water meter.

The water meter is installed on the outlet side of the control valve. The water meter uses a turbine to measure gallons of treated water. The turbine rotates with the flow of water and reports its rate of rotation through Hall effect² circuitry to the printed circuit (PC) board. This rotation permits the PC board to record the total volume of treated water and the flow rate. The small centrally located magnet is shielded from water, which substantially reduces iron-fouling problems with the turbine.

THIS WATER METER SHOULD NOT BE USED AS THE PRIMARY MONITORING DEVICE FOR CRITICAL OR HEALTH EFFECT APPLICATIONS.

OPERATING PRESSURES: 20 PSI MINIMUM / 125 PSI MAXIMUM • OPERATING TEMPERATURES: 40°F MINIMUM / 110°F MAXIMUM

The turbine is accurate to within $\pm 5\%$ over a wide operating flow rate range (0.25 gpm (0.95 lpm) up to control valve maximums) and has a very low pressure drop. Water used for regeneration is not metered. If the control valve is set to prefill the regenerant, water used between the prefill cycle up to the start of the regeneration cycle is metered. If the control valve is in regeneration mode (e.g. a backwash cycle) and there is a water demand, that water usage is not metered.

When facing the front of the control valve, the water meter is positioned on the left-hand side of the control valve. Allow sufficient clearance to clean and repair the water meter without disconnecting the plumbing or disassembling any other parts of the control valve.

Control valves can be ordered with a meter plug (i.e. no electronics or turbine) rather than a water meter if desired. Control valves without meters should only be set up for time clock operation (i.e. no water meter, no demand-initiated regeneration). Control valves with water meters provide a wider variety of useful information (see OEM General Programming Instructions for additional information).

Mixing Valve

The mixing valve is installed on the outlet side of the control valve. The mixing valve is used to blend raw water with treated water.

To adjust the blended water, close the mixing valve. Open a water faucet to the desired flow rate. Open the mixing valve until the desired hardness is reached. Close the faucet.

Installation Fitting Assemblies

The installation fittings are used to connect the optional bypass or the control valve to the plumbing system. See pages 18 and 19 for available fitting assemblies.

The installation fitting assemblies are sold in pairs and consist of two fittings, two nuts, two split rings and two o-rings. The installation fitting assemblies and the bypass valve are sold separately from the control valve.

Both elbow fittings have a unique drill out feature to allow a 1/4" NPT connection to the inlet and/or outlet which can be used for a RO feed, test ports, pressure tap ports, etc.

The installation fitting assemblies are sold in pairs and consist of two fittings, two nuts, two split rings and two o-rings. The installation fitting assemblies and the bypass valve are sold separately from the control valve.

Both elbow fittings have a unique drill out feature to allow a 1/4" NPT connection to the inlet and/or outlet which can be used for a RO feed, test ports, pressure tap ports, etc.

² Some semiconductor materials exhibit a phenomenon in the presence of a magnetic field that is adaptable to sensing devices. When a current is passed through one pair of wires attached to a semiconductor, another pair of wires properly attached and oriented with respect to the semiconductor will develop a voltage proportional to the magnetic field present and the current in the other pair of wires. Holding the exciting current constant and moving a permanent magnet near the semiconductor produces a voltage output proportional to the movement of the magnet. Hall effect devices provide a high speed response, excellent temperature stability, and no physical contact.

Bypass Valve

The bypass valve is typically used to isolate the control valve from the plumbing system's water pressure in order to perform control valve repairs or maintenance. The WS1 bypass valve is particularly unique in the water treatment industry due to its versatility and state of the art design features. The 1" full flow bypass valve incorporates four positions, including a diagnostic position that allows service personal to work on a pressurized system while still providing untreated bypass water to the facility or residence. Its completely non-metallic, all-plastic design allows for easy access and serviceability without the need for tools.

The bypass body and rotors are glass filled Noryl³ (or equivalent) and the nuts and caps are glass filled polypropylene. All seals are self-lubricating EPDM to help prevent valve seizing after long periods of non-use. Internal o-rings can easily be replaced if service is required.

The bypass consists of two interchangeable plug valves that are operated independently by red arrow-shaped handles. The handles identify the flow direction of the water. The plug valves enable the bypass valve to operate in four positions.

- 1. Normal Operation Position:** The inlet and outlet handles point in the direction of flow indicated by the engraved arrows on the control valve. Water flows through the control valve during normal operation and this position also allows the control valve to isolate the media bed during the regeneration cycle. (See Figure 1)
- 2. Bypass Position:** The inlet and outlet handles point to the center of the bypass, the control valve is isolated from the water pressure contained in the plumbing system. Untreated water is supplied to the plumbing system. (See Figure 2)
- 3. Diagnostic Position:** The inlet handle points in the direction of flow and the outlet handle points to the center of bypass valve, system water pressure is allowed to the control valve and the plumbing system while not allowing water to exit from the control valve to the plumbing. (See Figure 3)
- 4. Shut Off Position:** The inlet handle points to the center of the bypass valve and the outlet handle points in the direction of flow, the water is shut off to the plumbing system. If water is available on the outlet side of the softener it is an indication of water bypass around the system (i.e. a plumbing connection somewhere in the building bypasses the system). (See Figure 4)

³ Noryl is a trademark of Sabic.

Bypass Valve Operation

Figure 1

NORMAL OPERATION

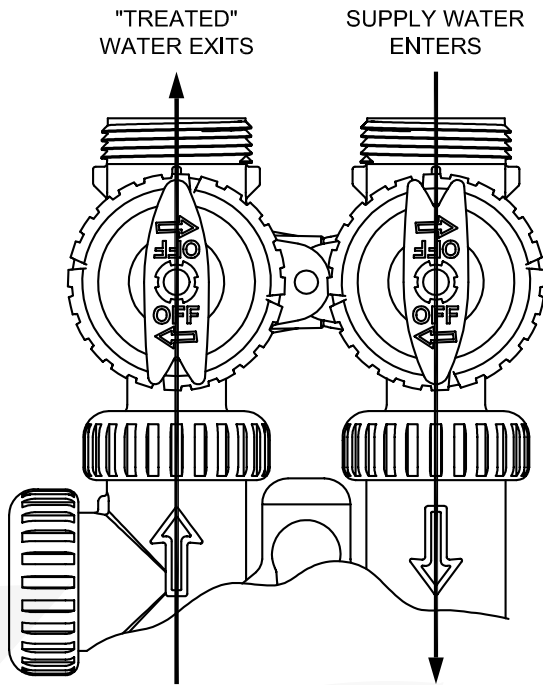

Figure 2

BYPASS OPERATION

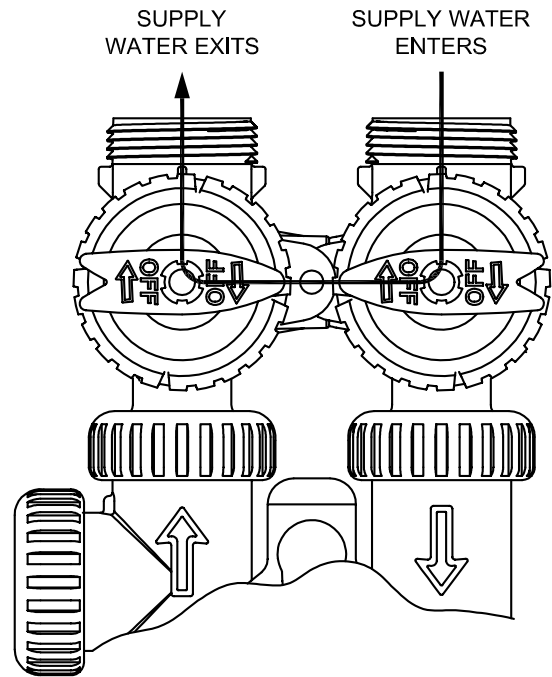

Figure 3

DIAGNOSTIC MODE

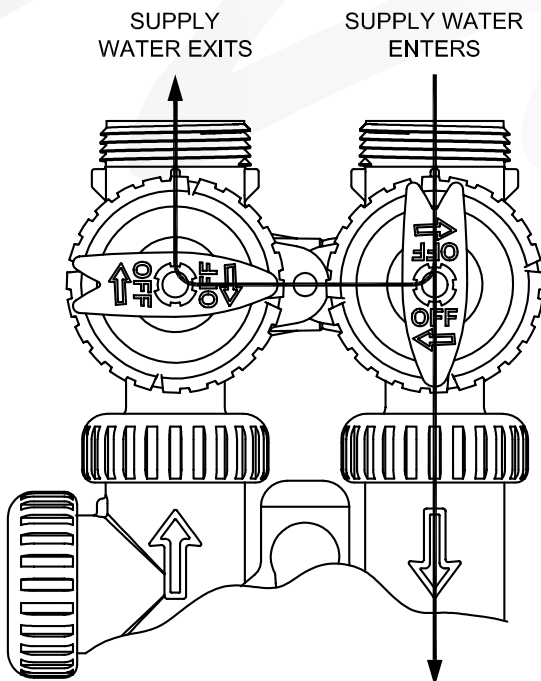
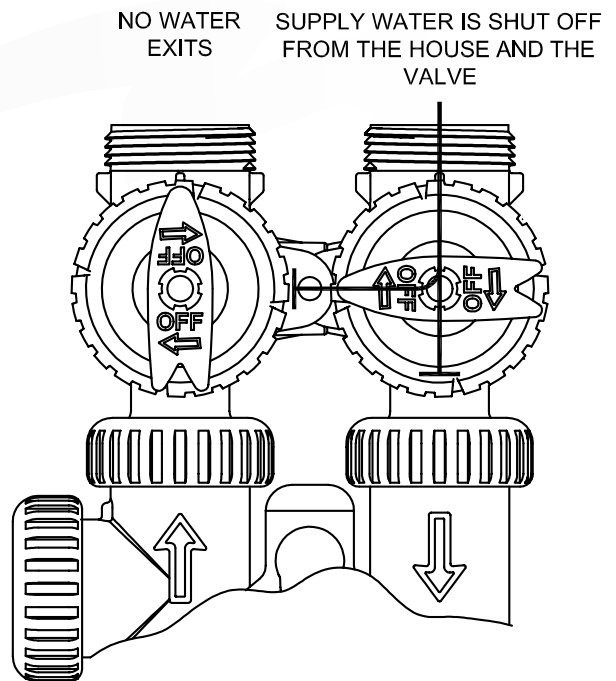

Figure 4

SHUT OFF MODE



Installation

Allow one foot of clearance to service the valve.

The valve will withstand transportation and storage temperatures of -13 °F (-25 °C) to 131 °F (55 °C) and for short periods up to 158 °F (70 °C). If valve has been exposed to freezing conditions let valve warm up to room temperature before running water through it. The valve has been packaged to prevent damage from the effects of normal humidity, vibration and shock.

Refill Flow Control Assembly or Refill Port Plug

Control valves that are setup for backwash only come equipped with a refill port plug. The refill port plug has no regenerant line connection.

Control valves that use a regenerant come equipped with a 3/8" refill flow control assembly. To switch to the 1/2" refill flow control assembly, remove the refill flow control and retainer (from the 3/8" refill elbow) by twisting and pulling out. Insert the refill flow control and retainer into the 1/2" refill elbow.

To complete the regenerant line connection, orientate the outlet in the desired direction and push the plastic insert into the polytube. Push the polytube into the nut. Do not use pipe dope or other sealants on threads. The threads for the compression nut do not need Teflon tape. Tighten the nut securely to create a pressure tight connection. A pliers or crescent wrench may be used to tighten or unscrew the nut. The nut, gripper and retainer sleeve is a 3 piece assembly that can come apart if removed from the elbow body. Parts must be reassembled exactly as shown in refill flow control assembly drawing to function properly. If the nut is completely removed from the body, slip the nut, plastic gripper and retainer sleeve on to the tube then tighten on to the fitting.

Drain Line Flow Control and Fitting Assembly

To determine which drain line flow control to use, obtain media bed expansion tables from the media manufacturer, choose a water temperature and look up the desired backwash rate per square foot of bed area. Then calculate the backwash rate using the desired tank diameter. Using the table (General Information page 5), choose the drain line flow control that has the backwash flow rate closest to the calculated backwash rate. If a manufacturer chooses to use an external drain line flow control, use an elbow fitting that does not contain a hole.

If the drain line is a 5/8" flexible polytube, slide the nut onto the polytube, then place the polytube insert into the end of the polytube and tighten the nut on to the 3/4" drain line fitting. The nut is only designed for use with flexible polytube. Use other nuts if attaching different materials.

To access the drain line flow control remove the locking clip by pulling it straight out. Pull fitting out and replace the locking clip so that it is not misplaced. The drain line fitting is pressed in and has an o-ring seal.

In the 3/4" elbow, the white flow control retainer is pressed in and has an o-ring seal. The retainer can be removed by rotating and pulling. The flow control can be removed by prying upward with a small blade flat screwdriver in one of the slots on the side. The drain line flow control and retainer can be chemically cleaned in dilute sodium bisulfite or vinegar, or replaced. Do not use a wire brush to clean the flow control or the washer. The washers are identified with three numbers, which correspond to the flow rate. When reinstalling make sure the identifying number and the rounded inside diameter on the washer is visible when seated in the retainer. The white flow control washer retainer can also be removed and cleaned. Push the retainer in firmly when reinstalling.

In the 1" straight fitting, the retainer is the fitting. Unscrew the nut to access the flow control. The drain line flow control and the fitting can be chemically cleaned or replaced. Do not use a wire brush to clean the flow control or the fitting.

Do not use Vaseline, oils, or other unacceptable lubricants on o-rings. A silicone lubricant may be used on the black o-ring. Use a pliers or crescent wrench to tighten or unscrew the nut. Do not use a pipe wrench to tighten or loosen nut. Do not use pipe dope or other sealants on threads. Use Teflon tape on the threads of the drain line control fitting when installing 3/4" NPT or 1" straight fitting.

Installation Fitting Assemblies

The installation fittings connect to the control valve or the bypass valve using nuts that only require hand tightening. Hand tighten nut connections between control valve and installation fittings, control valve and bypass valve, and bypass valve and installation fittings allow for easy serviceability. Do not use a pipe wrench to tighten nuts on installation fittings. Hand tighten only.

The split ring retainer design holds the nut on and allows load to be spread over the entire nut surface area, reducing the chance for leakage. The split ring design, incorporated into the installation fittings allows approximately 2 degrees off axis alignment to the plumbing system. The installation fittings are designed to accommodate minor plumbing misalignments but are not designed to support the weight of a system or the plumbing.

When assembling the installation fitting package, connect the fitting to the plumbing system first and then attach the nut, split ring and o-ring. Heat from soldering or solvent cements may damage the nut, split ring or o-ring. Solder joints should be cool and solvent cements should be set before installing the nut, split ring and o-ring. Avoid getting primer and solvent cement on any part of the o-rings, split rings, bypass valve or control valve. Solvent cements and primers should be used in accordance with the manufacturer's instructions.

Slip the nut onto the fitting first, then the split ring second and the o-ring last. Hand tighten the nut. If the fitting is leaking tightening the nut will not stop the leak. Remove the nut, remove the fitting, and check for damage or misalignment of the o-ring.

Do not use pipe dope or other sealant on threads. Use teflon tape on threaded inlet, outlet and drain fittings. Teflon tape is not necessary on the nut connection or caps because of o-ring seals.

Do not use Vaseline, oils, or other unacceptable lubricants on o-rings. A silicone lubricant may be used on black o-rings.

Bypass Valve

The bypass valve easily connects to the control valve body using nuts that only require hand tightening. Hand tighten nut connections between control valve and fittings, control valve and bypass valve, and bypass valve and installation fittings allow for easy serviceability. The split ring retainer design holds the nut on and allows load to be spread over the entire nut surface area, reducing the chance for leakage. The split ring design incorporated into the bypass allows approximately 2 degrees off axis alignment to the plumbing system. The bypass is designed to accommodate minor plumbing misalignments but is not designed to support the weight of a system or the plumbing.

Avoid getting primer and solvent cements on any part of the o-rings or split rings, bypass valve or control valve. Do not use pipe dope or other sealant on threads. Teflon tape is not necessary on the caps because of o-ring seals.

Do not use Vaseline, oils, or other unacceptable lubricants on o-rings. A silicone lubricant may be used on black o-rings.

Mixing Valve

The mixing valve is an option on the control valve. If the control valve is ordered with a mixing valve it will be installed in the control valve assembly process.

To adjust the blended water, close the mixing valve. Open a water faucet to the desired flow rate. Open the mixing valve until the desired hardness is reached. Close the faucet.

Note: The use of the mixing valve requires modification to the valve body. These modifications should not be done in the field.

Service Instructions



When servicing the valve, water may leak from the valve. Water from the valve may create a slip hazard. Clean up water spills.

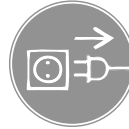

Disconnect from electrical power prior to servicing the valve.

Drive Assembly

Remove the valve cover to access the drive assembly.

Disconnect the power source plug (black wire) from the PC board prior to disconnecting the motor or water meter plugs from the PC board. The power source plug connects to the four-pin jack. The motor plug connects to the two-pin jack on the left-hand side of the PC board. The water meter plug (gray wire) connects to the three-pin jack on the far right-hand side of the PC board.

The PC board can be removed separately from the drive bracket but it is not recommended. Do not attempt to remove the display panel from the PC board. Handle the board by the edges. To remove the PC board from the drive bracket, unplug the power, water meter and motor plugs from the PC board. Lift the middle latch along the top of the drive bracket while pulling outward on the top of the PC board. The drive bracket has two plastic pins that fit into the holes on the lower edge of the PC board. Once the PC board is tilted about 45° from the drive bracket it can be lifted off of these pins. To reinstall the PC board, position the lower edge of the PC board so that the holes in the PC board line up with the plastic pins. Push the top of the PC board towards the valve until it snaps under the middle latch, weave the power and water meter wires into the holders and reconnect the motor, water meter and power plugs.

The drive bracket must be removed to access the drive cap assembly and pistons or the drive gear cover. It is not necessary to remove the PC board from the drive bracket to remove the drive bracket. To remove the drive bracket start by removing the plugs for the power source and the water meter. Unweave the wires from the side holders. Two tabs on the top of the drive back plate hold the drive bracket in place. Simultaneously lift the two tabs and gently ease the top of the drive bracket forward. The lower edge of the drive bracket has two notches that rest on the drive back plate. Lift up and outward on the drive bracket to disengage the notches.

To reassemble, seat the bottom of the drive bracket so the notches are engaged at the bottom of the drive back plate. Push the top of the drive bracket toward the two latches. The drive bracket may have to be lifted slightly to let the threaded piston rod pass through the hole in the drive bracket. Maintain a slight engaging force on top of the drive bracket while deflecting the bracket slightly to the left by pressing on the side of the upper right corner. This helps the drive gears mesh with the drive cap assembly. The drive bracket is properly seated when it snaps under the latches on the drive back plate. If resistance is felt before latching, then notches are not fully engaged, the piston rod is not in hole, the wires are jammed between the drive bracket and drive back plate, or the gear is not engaging the drive cap assembly.

To inspect the drive gears, the drive gear cover needs to be removed. Before trying to remove the gear cover, the drive bracket must be removed from the drive back plate. (Refer to the instructions above regarding removing the drive bracket from the drive back plate. The drive gear cover can be removed from the drive bracket without removing the motor or the PC board.) The drive gear cover is held in place on the drive bracket by three clips. The largest of the three clips is always orientated to the bottom of the drive bracket. With the PC board facing up, push in and down on the large clip on the drive gear cover. Handle the cover and the gears carefully so that the gears do not fall off the pegs in the cover.

Replace broken or damaged drive gears. Do not lubricate any of the gears. Avoid getting any foreign matter on the reflective coating because dirt or oils may interfere with pulse counting.

The drive gear cover only fits on one way, with the large clip orientated towards the bottom. If all three clips are outside of the gear shroud on the drive bracket the drive gear cover slips easily into place.

The drive bracket does not need to be removed from the drive plate if the motor needs to be removed. To remove the motor, disconnect the power and motor plugs from the jacks on the PC board. Move the spring clip loop to the right and hold. Rotate the motor at least a ¼ turn in either direction so the wires are vertical (up & down) before gently pulling on the wire connectors to remove the motor. Pulling directly on the wires without rotating the motor may break the wires off the motor.

Replace the motor if necessary. Do not lubricate the motor or the gears. To reinstall the motor, move the spring clip loop to the right and hold. Gently turn the motor while inserting so that the gear on the motor meshes with the gears under the drive gear cover. Release the spring clip loop and continue to rotate the motor until the wires are horizontal and the motor housing engages the small plastic bulge inside the drive bracket motor retainer. Reconnect the motor plug to the two-pronged jack on the lower left side of the PC board. If the motor will not easily engage with the drive gears when reinstalling, lift and slightly rotate the motor before reinserting. Reconnect the power plug.

Replace the valve cover. After completing any valve maintenance involving the drive assembly or the drive cap assembly and pistons unplug power source jack from the printed circuit board (black wire) and plug back in or:

- For valves that use a TC circuit board (three buttons) press and hold SET and DOWN buttons for 3 seconds. The cover button may have other names like “SET HOUR”, “CLOCK” or “SET CLOCK” but the circuit board is labeled with SET.
- For all other valves press and hold NEXT and REGEN buttons for 3 seconds.

This resets the electronics and establishes the service piston position. The display should flash all wording, then flash the software version and then reset the valve to the service position.

Drive Cap Assembly, Main Piston and Regenerant Piston

The drive assembly must be removed to access the drive cap assembly. The drive cap assembly must be removed to access the piston(s). The drive cap assembly is threaded into the control valve body and seals with an o-ring. To remove the drive cap assembly use the special plastic wrench or insert a ¼” to ½” flat blade screwdriver into one of the slots around the top 2” of the drive cap assembly so it engages the notches molded into the drive back plate around the top 2” of the piston cavity. See Figure 5. The notches are visible through the holes. Lever the screwdriver so the drive cap assembly turns counter clockwise. Once loosened unscrew the drive cap assembly by hand and pull straight out.

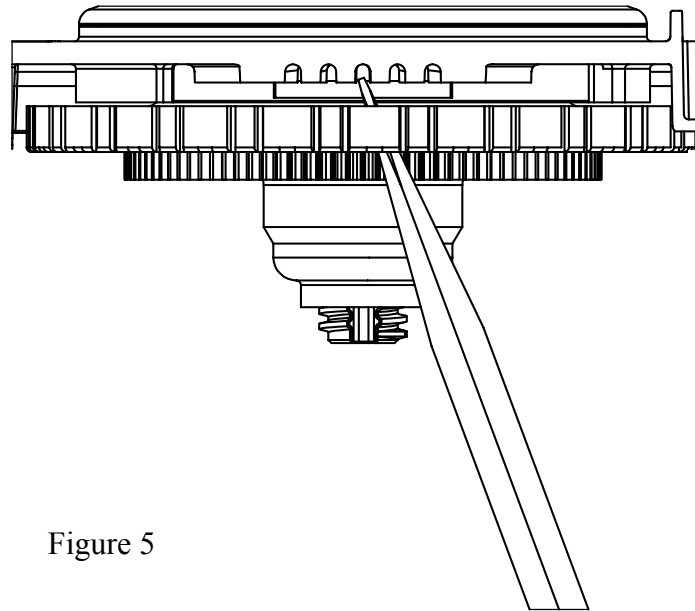

Figure 5

The drive cap assembly contains the drive cap, the main drive gear, drive cap spline, piston rod and various other parts that should not be disassembled in the field. The only replaceable part on the drive cap assembly is the o-ring. Attached to the drive cap assembly is the main piston (downflow or upflow) and if a regenerant is used, a regenerant piston. Upflow is not applicable to EE, EI, or TC WS1 and WS1.25 control valves.

The regenerant piston (the small diameter one behind the main piston) is removed from the main piston by pressing sideways and unsnapping it from its latch. Chemically clean in dilute sodium bisulfite or vinegar, or replace the regenerant piston if needed. To remove the main piston fully extend the piston rod and then unsnap the main piston from its latch by pressing on the side with the number. Chemically clean in dilute sodium bisulfite or vinegar, or replace the main piston.

Reattach the main piston to the drive cap assembly. Reattach the regenerant piston (if needed) to the main piston. Reinsert the drive cap assembly and piston into the spacer stack assembly and hand tighten the drive cap assembly. Continue to tighten the drive cap assembly using a screwdriver as a ratchet until the black o-ring on the spacer stack assembly is no longer visible through the drain port. Excessive force can break the notches molded into the drive back plate. Make certain that the main drive gear still turns freely. The exact position of the piston is not important as long as the main drive gear turns freely.

Reattach the drive assembly to the control valve and connect all plugs. After completing any valve maintenance involving the drive assembly or the drive cap assembly and pistons unplug power source jack from the printed circuit board (black wire) and plug back in or:

- For valves that use a TC circuit board (three buttons) press and hold SET and DOWN buttons for 3 seconds. The cover button may have other names like “SET HOUR”, “CLOCK” or “SET CLOCK” but the circuit board is labeled with SET.
- For all other valves press and hold NEXT and REGEN buttons for 3 seconds.

This resets the electronics and establishes the service piston position. The display should flash all wording, then flash the software version and then reset the valve to the service position.

Note: To identify main piston refer to page 13 (not applicable for control valves that use a quick connect tank adapter).

Spacer Stack Assembly

For spacer stack identification refer to page 13 (not applicable for control valves that use a quick connect tank adapter).

To access the spacer stack assembly remove the drive assembly, drive cap assembly and piston. The spacer stack assembly can be removed easily without tools by using thumb and forefinger. Inspect the black o-rings and clear lip seals for wear or damage. Replace the entire stack if necessary. Do not disassemble the WS1 or WS1.25 stack.

The spacer stack assembly may be chemically cleaned (dilute sodium bisulfite or vinegar) or wiped with a soft cloth.

The spacer stack assembly can be pushed in to the control valve body bore by hand. Since the spacer stack assembly can be compressed it is easier to use a blunt object (5/8” to 1-1/8” in diameter) to push the center of the assembly into the control valve body. The assembly is properly seated when at least four threads are exposed (approximately 5/8”). Do not force the spacer stack assembly in. The control valve body bore interior can be lubricated with silicone to allow for easy insertion of the entire stack.

Reattach the drive cap assembly and piston(s) and the drive assembly.

After completing any valve maintenance involving the drive assembly or the drive cap assembly and pistons unplug power source jack from the printed circuit board (black wire) and plug back in or:

- For valves that use a TC circuit board (three buttons) press and hold SET and DOWN buttons for 3 seconds. The cover button may have other names like “SET HOUR”, “CLOCK” or “SET CLOCK” but the circuit board is labeled with SET.
- For all other valves press and hold NEXT and REGEN buttons for 3 seconds.

This resets the electronics and establishes the service piston position. The display should flash all wording, then flash the software version and then reset the valve to the service position.

Injector Cap, Screen, Injector Plug and Injector

Unscrew the injector cap and lift off. Loosen cap with special plastic wrench or pliers if necessary. Attached to the injector cap is a screen. Remove the screen and clean if fouled.

The plug and/or injector can be pried out with a small screwdriver. The plug can be wiped clean. If the plug leaks replace the entire plug. The injector consists of a throat and a nozzle. Chemically clean the injector with vinegar or sodium bisulfite. The holes can be blown out with air. Both pieces have small diameter holes that control the flow rates of water to insure that the proper concentration of regenerant is used. Sharp objects, which can score the plastic, should not be used to clean the injector. Scoring the injector or increasing the diameter of the hole could change the operating parameters of the injector.

Two holes are labeled DN and UP. Check for compliance. Refer to Valve Body Compliance Table at the beginning of this manual.

Push the plug(s) and/or injectors firmly in place, replace the screen and hand tighten the injector cap.

Refill Flow Control Assembly or Refill Port Plug

To clean or replace the refill flow control, pull out the elbow-locking clip and then pull straight up on the elbow. Replace the elbow locking clip in the slot so that it is not misplaced. Twist to remove the white flow control retainer. The flow control can be removed by prying upward through the side slots of the retainer with a small flat blade screwdriver.

Chemically clean the flow control or the white flow control retainer using dilute sodium bisulfite or vinegar. Do not use a wire brush. If necessary, replace the flow control, o-ring on the flow control retainer, or the o-ring on the elbow.

Reseat the flow control so the rounded end is visible in the flow control. Reseat the white flow control retainer by pushing the retainer into the elbow until the o-ring seats. Remove locking clip, push down on elbow to reseat and insert locking clip.

Do not use Vaseline, oils, or other unacceptable lubricants on o-rings. A silicone lubricant may be used on the o-ring on the elbow or the white retainer.

Water Meter or Meter Plug

The water meter assembly is connected to the PC board by a wire. If the entire water meter assembly is to be replaced, remove the control valve cover and disconnect the power source and water meter plugs from the PC board. Unlatch the drive assembly and lean it forward. Unthread the water meter wire from the side of the drive assembly and through the drive back plate. To reinstall, rethread the water meter wire through the drive back plate and the side of the drive assembly. Reattach the drive assembly and the water meter and power plugs.

THIS WATER METER SHOULD NOT BE USED AS THE PRIMARY MONITORING DEVICE FOR CRITICAL OR HEALTH EFFECT APPLICATIONS.

OPERATING PRESSURES: 20 PSI MINIMUM / 125 PSI MAXIMUM • OPERATING TEMPERATURES: 40°F MINIMUM / 110°F MAXIMUM

If no water meter wire is visible, then a plug is installed, not a water meter.

The water meter wire does not need to be removed from the PC board if the water meter is only being inspected and cleaned. To remove the water meter assembly, unscrew the meter cap on the left side of the control valve. Pliers may be used to unscrew the nut if necessary.

With the nut removed, a slot at the top of the water meter is visible. Twist a flat blade screwdriver in the slot between the control valve body and the meter. When the meter is part way out it is easy to remove the water meter from the housing. Once the water meter is removed from the control valve body, gently pull forward on the turbine to remove it from the shaft.

Do not use a wire brush to clean the turbine. Wipe with a clean cloth or chemically clean in dilute sodium bisulfite or vinegar. The turbine can be immersed in the chemical. Do not immerse electronics. If the turbine is scored or damaged or the bearings on the turbine are worn, replace the turbine.

Do not lubricate the turbine shaft. The turbine shaft bearings are prelubricated. Do not use Vaseline, oils, or other unacceptable lubricants on the o-ring. A silicone lubricant may be used on the black o-ring.

Snap the turbine on the shaft and reinsert the water meter into the side slot. Hand tighten the nut. Do not use a pipe wrench to tighten nut.

Mixing Valve

To clean or replace the mixing valve, unthread the mixing valve from the valve body. Chemically clean the mixing valve with a dilute sodium bisulfite or vinegar solution. Do not use Vaseline, oils, or other unacceptable lubricants on o-rings. A silicone lubricant may be used on the o-ring. Before replacing the mixing valve in the valve body turn the knob clockwise so that the mixing valve is in the open position. Failure to do this may cause damage to the mixing valve when it is screwed in to the valve body.

To adjust the blended water, close the mixing valve. Open a water faucet to the desired flow rate. Open the mixing valve until the desired hardness is reached. Close the faucet.

Bypass Valve

The working parts of the bypass valve are the rotor assemblies that are contained under the bypass valve caps. Before working on the rotors, make sure the system is depressurized. Turn the red arrow shaped handles towards the center of the bypass valve and back several times to ensure rotor is turning freely.

The nuts and caps are designed to be unscrewed or tightened by hand. If necessary a pliers can be used to unscrew the nut or cap. Do not use a pipe wrench to tighten or loosen nuts or caps. Do not place screwdriver in slots on caps and/or tap with a hammer. To access the rotor, unscrew the cap and lift the cap, rotor and handle out as one unit. Twisting the unit as you pull it out will help to remove it more easily. There are three o-rings: one under the rotor cap, one on the rotor stem and the rotor seal. Replace worn o-rings. Clean rotor. Reinstall rotor.

When reinstalling the red arrow handles be sure that:

1. The handle pointers are lined up with the control valve body arrows, and the rotor seal o-ring and retainer on both rotors face to the right when being viewed from the front of the control valve; or
2. Arrows point toward each other in the bypass position.

Since the handles can be pulled off, they could be accidentally reinstalled 180° from their correct orientation. To install the red arrow handles correctly, keep the handles pointed in the same direction as the arrows engraved on the control valve body while tightening the bypass valve caps.

After completing any valve maintenance involving the drive assembly or the drive cap assembly and pistons unplug power source jack from the printed circuit board (black wire) and plug back in or:

- For valves that use a TC circuit board (three buttons) press and hold SET and DOWN buttons for 3 seconds. The cover button may have other names like "SET HOUR", "CLOCK" or "SET CLOCK" but the circuit board is labeled with SET.
- For all other valves press and hold NEXT and REGEN buttons for 3 seconds.

This resets the electronics and establishes the service piston position. The display should flash all wording, then flash the software version and then reset the valve to the service position.

Troubleshooting

TC control valves do not have meters so shaded areas are not applicable for TC control valves

Problem	Possible Cause	Solution
1. No Display on PC Board	a. No power at electric outlet	a. Repair outlet or use working outlet
	b. Control valve Power Adapter not plugged into outlet or power cord end not connected to PC board connection	b. Plug Power Adapter into outlet or connect power cord end to PC Board connection
	c. Improper power supply	c. Verify proper voltage is being delivered to PC Board
	d. Defective Power Adapter	d. Replace Power Adapter
	e. Defective PC Board	e. Replace PC Board
2. PC Board does not display correct time of day	a. Power Adapter plugged into electric outlet controlled by light switch	a. Use uninterrupted outlet
	b. Tripped breaker switch and/or tripped GFI	b. Reset breaker switch and/ or GFI switch
	c. Power outage	c. Reset time of day. If PC Board has battery back up present the battery may be depleted. See Front Cover and Drive Assembly drawing for instructions.
	d. Defective PC Board	d. Replace PC Board
3. Display does not indicate that water is flowing. Refer to user instructions for how the display indicates water is flowing	a. Bypass valve in bypass position	a. Turn bypass handles to place bypass in service position
	b. Meter is not connected to meter connection on PC Board	b. Connect meter to three pin connection labeled METER on PC Board
	c. Restricted/ stalled meter turbine	c. Remove meter and check for rotation or foreign material
	d. Meter wire not installed securely into three pin connector	d. Verify meter cable wires are installed securely into three pin connector labeled METER
	e. Defective meter	e. Replace meter
	f. Defective PC Board	f. Replace PC Board
4. Control valve regenerates at wrong time of day	a. Power outage	a. Reset time of day. If PC Board has battery back up present the battery may be depleted. See Front Cover and Drive Assembly drawing for instructions.
	b. Time of day not set correctly	b. Reset to correct time of day
	c. Time of regeneration set incorrectly	c. Reset regeneration time
	d. Control valve set at “on 0” (immediate regeneration)	d. Check programming setting and reset to NORMAL (for a delayed regen time)
	e. Control valve set at “NORMAL + on 0” (delayed and/ or immediate)	e. Check programming setting and reset to NORMAL (for a delayed regen time)
5. Time of day flashes on and off	a. Power outage	a. Reset time of day. If PC Board has battery back up present the battery may be depleted. See Front Cover and Drive Assembly drawing for instructions.
6. Control valve does not regenerate automatically when the correct button(s) is depressed and held. For TC valves the buttons are ▲&▼. For all other valves the button is REGEN	a. Broken drive gear or drive cap assembly	a. Replace drive gear or drive cap assembly
	b. Broken Piston Rod	b. Replace piston rod
	c. Defective PC Board	c. Defective PC Board
7. Control valve does not regenerate automatically but does when the correct button(s) is depressed and held. For TC valves the buttons are ▲&▼. For all other valves the button is REGEN	a. Bypass valve in bypass position	a. Turn bypass handles to place bypass in service position
	b. Meter is not connected to meter connection on PC Board	b. Connect meter to three pin connection labeled METER on PC Board
	c. Restricted/ stalled meter turbine	c. Remove meter and check for rotation or foreign material
	d. Incorrect programming	d. Check for programming error
	e. Meter wire not installed securely into three pin connector	e. Verify meter cable wires are installed securely into three pin connector labeled METER
	f. Defective meter	f. Replace meter
	g. Defective PC Board	g. Replace PC Board

Problem	Possible Cause	Solution
8. Hard or untreated water is being delivered	a. Bypass valve is open or faulty	a. Fully close bypass valve or replace
	b. Media is exhausted due to high water usage	b. Check program settings or diagnostics for abnormal water usage
	c. Meter not registering	c. Remove meter and check for rotation or foreign material
	d. Water quality fluctuation	d. Test water and adjust program values accordingly
	e. No regenerant or low level of regenerant in regenerant tank	e. Add proper regenerant to tank
	f. Control fails to draw in regenerant	f. Refer to Trouble Shooting Guide number 12
	g. Insufficient regenerant level in regenerant tank	g. Check refill setting in programming. Check refill flow control for restrictions or debris and clean or replace
	h. Damaged seal/stack assembly	h. Replace seal/stack assembly
	i. Control valve body type and piston type mix matched	i. Verify proper control valve body type and piston type match
	j. Fouled media bed	j. Replace media bed
9. Control valve uses too much regenerant	a. Improper refill setting	a. Check refill setting
	b. Improper program settings	b. Check program setting to make sure they are specific to the water quality and application needs
	c. Control valve regenerates frequently	c. Check for leaking fixtures that may be exhausting capacity or system is undersized
10. Residual regenerant being delivered to service	a. Low water pressure	a. Check incoming water pressure – water pressure must remain at minimum of 25 psi
	b. Incorrect injector size	b. Replace injector with correct size for the application
	c. Restricted drain line	c. Check drain line for restrictions or debris and clean
11. Excessive water in regenerant tank	a. Improper program settings	a. Check refill setting
	b. Plugged injector	b. Remove injector and clean or replace
	c. Drive cap assembly not tightened in properly	c. Re-tighten the drive cap assembly
	d. Damaged seal/ stack assembly	d. Replace seal/ stack
	e. Restricted or kinked drain line	e. Check drain line for restrictions or debris and or un-kink drain line
	f. Plugged backwash flow controller	f. Remove backwash flow controller and clean or replace
	g. Missing refill flow controller	g. Replace refill flow controller
12. Control valve fails to draw in regenerant	a. Injector is plugged	a. Remove injector and clean or replace
	b. Faulty regenerant piston	b. Replace regenerant piston
	c. Regenerant line connection leak	c. Inspect regenerant line for air leak
	d. Drain line restriction or debris cause excess back pressure	d. Inspect drain line and clean to correct restriction
	e. Drain line too long or too high	e. Shorten length and or height
	f. Low water pressure	f. Check incoming water pressure – water pressure must remain at minimum of 25 psi

Problem	Possible Cause	Solution
<p>13. Water running to drain</p>	<p>a. Power outage during regeneration</p>	<p>a. Upon power being restored control will finish the remaining regeneration time. Reset time of day.</p>
	<p>b. Damaged seal/ stack assembly</p>	<p>b. Replace seal/ stack assembly</p>
	<p>c. Piston assembly failure</p>	<p>c. Replace piston assembly</p>
	<p>d. Drive cap assembly not tightened in properly</p>	<p>d. Re-tighten the drive cap assembly</p>
<p>14. E1, Err – 1001, Err – 101 = Control unable to sense motor movement</p>	<p>a. Motor not inserted full to engage pinion, motor wires broken or disconnected</p>	<p>a. Disconnect power, make sure motor is fully engaged, check for broken wires, make sure two pin connector on motor is connected to the two pin connection on the PC Board labeled MOTOR. Press NEXT and REGEN buttons for 3 seconds to resynchronize software with piston position or disconnect power supply from PC Board for 5 seconds and then reconnect.</p>
	<p>b. PC Board not properly snapped into drive bracket</p>	<p>b. Properly snap PC Board into drive bracket and then Press NEXT and REGEN buttons for 3 seconds to resynchronize software with piston position or disconnect power supply from PC Board for 5 seconds and then reconnect.</p>
	<p>c. Missing reduction gears</p>	<p>c. Replace missing gears</p>
<p>15. E2, Err – 1002, Err – 102 = Control valve motor ran too short and was unable to find the next cycle position and stalled</p>	<p>a. Foreign material is lodged in control valve</p>	<p>a. Open up control valve and pull out piston assembly and seal/ stack assembly for inspection. Press NEXT and REGEN buttons for 3 seconds to resynchronize software with piston position or disconnect power supply from PC Board for 5 seconds and then reconnect.</p>
	<p>b. Mechanical binding</p>	<p>b. Check piston and seal/ stack assembly, check reduction gears, check drive bracket and main drive gear interface. Press NEXT and REGEN buttons for 3 seconds to resynchronize software with piston position or disconnect power supply from PC Board for 5 seconds and then reconnect.</p>
	<p>c. Main drive gear too tight</p>	<p>c. Loosen main drive gear. Press NEXT and REGEN buttons for 3 seconds to resynchronize software with piston position or disconnect power supply from PC Board for 5 seconds and then reconnect.</p>
	<p>d. Improper voltage being delivered to PC Board</p>	<p>d. Verify that proper voltage is being supplied. Press NEXT and REGEN buttons for 3 seconds to resynchronize software with piston position or disconnect power supply from PC Board for 5 seconds and then reconnect.</p>

Problem	Possible Cause	Solution
16. E3, Err – 1003, Err – 103 = Control valve motor ran too long and was unable to find the next cycle position	a. Motor failure during a regeneration	a. Check motor connections then Press NEXT and REGEN buttons for 3 seconds to resynchronize software with piston position or disconnect power supply from PC Board for 5 seconds and then reconnect.
	b. Foreign matter built up on piston and stack assemblies creating friction and drag enough to time out motor	b. Replace piston and stack assemblies. Press NEXT and REGEN buttons for 3 seconds to resynchronize software with piston position or disconnect power supply from PC Board for 5 seconds and then reconnect.
	c. Drive bracket not snapped in properly and out enough that reduction gears and drive gear do not interface	c. Snap drive bracket in properly then Press NEXT and REGEN buttons for 3 seconds to resynchronize software with piston position or disconnect power supply from PC Board for 5 seconds and then reconnect.
17. Err – 1004, Err – 104 = Control valve motor ran too long and timed out trying to reach home position	a. Drive bracket not snapped in properly and out enough that reduction gears and drive gear do not interface	a. Snap drive bracket in properly then Press NEXT and REGEN buttons for 3 seconds to resynchronize software with piston position or disconnect power supply from PC Board for 5 seconds and then reconnect.
18. Err -1006, Err – 106, Err - 116 = MAV/ SEPS/ NHBP/ AUX MAV valve motor ran too long and unable to find the proper park position Motorized Alternating Valve = MAV Separate Source = SEPS No Hard Water Bypass = NHBP Auxiliary MAV = AUX MAV	a. Control valve programmed for ALT A or b, nHbP, SEPS, or AUX MAV with out having a MAV or NHBP valve attached to operate that function	a. Press NEXT and REGEN buttons for 3 seconds to resynchronize software with piston position or disconnect power supply from PC Board for 5 seconds and then reconnect. Then re-program valve to proper setting
	b. MAV/ NHBP motor wire not connected to PC Board	b. Connect MAV/ NHBP motor to PC Board two pin connection labeled DRIVE. Press NEXT and REGEN buttons for 3 seconds to resynchronize software with piston position or disconnect power supply from PC Board for 5 seconds and then reconnect.
	c. MAV/ NHBP motor not fully engaged with reduction gears	c. Properly insert motor into casing, do not force into casing Press NEXT and REGEN buttons for 3 seconds to resynchronize software with piston position or disconnect power supply from PC Board for 5 seconds and then reconnect.
	d. Foreign matter built up on piston and stack assemblies creating friction and drag enough to time out motor	d. Replace piston and stack assemblies. Press NEXT and REGEN buttons for 3 seconds to resynchronize software with piston position or disconnect power supply from PC Board for 5 seconds and then reconnect.
19. Err – 1007, Err – 107, Err - 117 = MAV/ SEPS/ NHBP/ AUX MAV valve motor ran too short (stalled) while looking for proper park position Motorized Alternating Valve = MAV Separate Source = SEPS No Hard Water Bypass = NHBP Auxiliary MAV = AUX MAV	a. Foreign material is lodged in MAV/ NHBP valve	a. Open up MAV/ NHBP valve and check piston and seal/ stack assembly for foreign material. Press NEXT and REGEN buttons for 3 seconds to resynchronize software with piston position or disconnect power supply from PC Board for 5 seconds and then reconnect.
	b. Mechanical binding	b. Check piston and seal/ stack assembly, check reduction gears, drive gear interface, and check MAV/ NHBP black drive pinion on motor for being jammed into motor body. Press NEXT and REGEN buttons for 3 seconds to resynchronize software with piston position or disconnect power supply from PC Board for 5 seconds and then reconnect.

Revision History:**9/5/2013****PAGE 4:**

Changes to table

3/12/2014**PAGE 18/19:**

Add V3007-16, V3007-17 Fitting Assemblies

6/17/2014**PAGE 26 AND 32:**

Noryl is a trademark of Sabic.

PAGE 34:

Allow one foot of clearance to service the valve.

The valve will withstand transportation and storage temperatures of -13 °F (-25 °C) to 131 °F (55 °C) and for short periods up to 158 °F (70 °C). If valve has been exposed to freezing conditions let valve warm up to room temperature before running water through it. The valve has been packaged to prevent damage from the effects of normal humidity, vibration and shock.

PAGE 36:

Slip Hazard Symbol and text

Disconnect electrical power symbol and text





CLACK CORPORATION
FIVE-YEAR SOFTENER AND FILTER CONTROLS
LIMITED WARRANTY

Clack Corporation (“Clack”) warrants to OEM that its Softener and Filter Control Valves will be free from defects in material and workmanship under normal use and service for a period of five years from the date of shipment of such Valves from Clack’s plant in Windsor, Wisconsin when installed and operated within recommended parameters. No warranty is made with respect to defects not reported to Clack within the warranty period and/or defects or damages due to neglect, misuse, alterations, accident, misapplication, physical damage, or damage caused by fire, acts of God, freezing or hot water or similar causes. For outdoor installations where the Softener and Filter Control Valves are not under cover, the weather cover must be utilized for the warranty to be valid.

Clack’s obligation to OEM under this Limited Warranty shall be limited, at its option, to replacement or repair of any Softener and Filter Control valve covered by this Limited Warranty. Prior to returning a Control Valve, OEM must obtain a return goods authorization number from Clack and return the Control Valve freight prepaid. If any Control Valve is covered under this Limited Warranty, Clack shall return the Control Valve repaired, or its replacement, prepaid to the original point of shipment.

CLACK GIVES THIS WARRANTY TO OEM IN LIEU OF ALL OTHER WARRANTIES, EXPRESS OR IMPLIED, INCLUDING WITHOUT LIMITATION ANY IMPLIED WARRANTIES OF MERCHANTABILITY OR FITNESS FOR A PARTICULAR PURPOSE AND HEREBY EXPRESSLY DISCLAIMS ALL OTHER SUCH WARRANTIES. CLACK’S LIABILITY HERE UNDER SHALL NOT EXCEED THE COST OF THE PRODUCT. UNDER NO CIRCUMSTANCES WILL CLACK BE LIABLE FOR ANY INCIDENTAL OR CONSEQUENTIAL DAMAGES OR FOR ANY OTHER LOSS, DAMAGE OR EXPENSE OF ANY KIND, INCLUDING LOSS OF PROFITS, ARISING IN CONNECTION WITH THE INSTALLATION OR USE OR INABILITY TO USE THE CONTROL VALVES OR ANY WATER TREATMENT SYSTEM THE CONTROL VALVE IS INCORPORATED INTO.